

16PR15269
15 March 2000

F-16 A/B MID-LIFE UPDATE
PRODUCTION TAPE M2
THE
PILOT'S GUIDE
to new capabilities & cockpit enhancements



F33657-94-C-2259
ECP 2242/2242-1
CDRL D034

Releasability of this material under the Freedom of Information Act is subject to the restrictions on release in DoD regulation 5400.7-R and DoD Directive 5230.25

Copyright © 2000 by Lockheed Martin Corporation
All rights reserved.

This material may be reproduced by the U.S. Government pursuant to the copyright license under the clause at DFARS 252.227-7013 (October 1988).

CODE IDENT: 81755

F-16 A/B MID-LIFE UPDATE
PRODUCTION TAPE M2
THE
PILOT'S GUIDE

to new capabilities & cockpit enhancements

F33657-94-C-2259

ECP 2242/2242-1

CDRL D034

Prepared by:

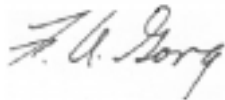

F. A. Gorg
Pilot-Vehicle Interface

Reviewed by:



S. E. Darland
Pilot-Vehicle Interface M2/M2+ Lead

Reviewed by:



Gary L. Kolling
Avionics System Requirements

Approved by:

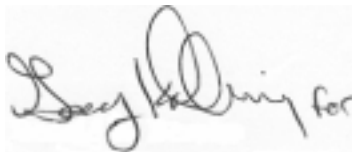

Ronald R. Bessire
M2/M2+ Program Manager

Releasability of this material under the Freedom of Information Act is subject to the
Restrictions on release in DoD Regulation 5400.7-R and DoD and DoD Directive 5230.25

Copyright © 2000 by Lockheed Martin Corporation.
All rights reserved.

This material may be reproduced by or for the U.S. Government pursuant to the copyright license under the clause at
DFARS 252.227-7013 (October 1988)

Table of Contents

Description	Page
INTRODUCTION	1
SECTION 1 - GENERAL	3
Core Avionics Provisions (RDP-052)	3
Avionics Selection After MMC Power Cycle (RDP-1367)	3
Jettison Delay For 600 Gallon Tanks (RDP-2000)	3
AN/ARC-186R VHF Radio 8.33 kHz Channel Spacing (RDP-1701)	3
Autonomous ACMI (RDP-867)	4
Color Display Optimization (RDP-1054)	5
Color Data Linked Information Outside The HSD FOV (RDP-884)	7
MFD Horizon Line Incorrect When Inverted (RDP-1246)	8
MFD Contrast/Brightness Control (RDP-1160)	9
MFD Display Gain Control Option Incorporation (RDP-1703)	11
Reduced Size Of FCR Symbology (RDP-925)	11
GPS Time Available On Bus/GPS Time Use (RDP-1159)	12
SECTION 2 - NAVIGATION	13
Digital Terrain System (DTS) Phase II (RDP-1077)	13
DBTC Whiskers (RDP-1510)	21
Roll Stabilized DTS DBTC Cue (RDP-1244)	21
HSD Freeze Enhancements (RDP-1053)	21
HSD Declutter By Master Mode (RDP-972)	23
Identify The Active Navigation Route (RDP-1002)	24
NVP Boresight And Faults (RDP-1169)	24
NVP Laser Spot Locator (RDP-1171)	25
Include Current Master Mode In DTE Load (RDP-314)	25
Hands-On Declutter Of HUD Symbology (Landing Phase) (RDP-869)	26
Time-Over-Steerpoint (TOS) Refinements (RDP-259)	26
UTM Coordinate Entry Up To Four Digits (RDP-597)	28
SECTION 3 - AIR-TO-AIR	29
AIFF Mode Interrogation Enhancement (RDP-878)	30
Auto Time Mode Enhancement (RDP-879)	30
AIFF Interrogator Coupling To IFF Transponder Modes (RDP-1235); AIFF Changes And AIFF Target Display Conflict (RDP-1702)	30
SCAN/LOS Mechanization (RDP-1236)	34
IFF Mode Number Inside AIFF Response Symbology (RDP-1237)	34
Improved IDM Mechanization (RDP-1366)	35
IDM Automatic Target Hand-Off System (ATHS) (RDP-868)	35
IDM-Allow A/A Target Assignments In Continuous Mode (RDP-875)	40
Highlight CONT Mnemonic To Indicate Active CONT Operation (RDP-1239)	40

TABLE OF CONTENTS (Con't)

IDM-Expand Net Size To 8 Members (RDP-872)	40
IDM SEAD Changes (RDP-1015)	41
ASSIGN Message In HUD (RDP-1242)	42
Ownship Symbol Occlusion By Team Member Data Link Symbols On HSD (RDP-1241)	42
IDM Messages Zeroize (RDP-983)	42
Flexible Data Link Steerpoints (71-80) (RDP-873)	42
ACM-One Switch Action To NO-RAD (RDP-626)	43
Bug Stepping To Track Files Limited To Selected Range (RDP-1158)	43
SAM Multi-Track (SMT) Mode Transfer Remechanization (RDP-1165)	43
Breaklock Reacquisition Symbology In SAM (RDP-1243)	44
Cursor Digital Search Altitude Information (RDP-351)	44
HUD Ownship Bull's-Eye (RDP-1229)	44
Update Bull's-Eye Position In Expand (RDP-1415)	45
LANTIRN Targeting Pod Interface (RDP-864)	45
Attitude Awareness In DGFT (RDP-820)	47
Target Altitude In HUD (RDP-1361)	49
Heads Up Indication Of Imminent Radar Break Track (RDP-1049)	49
EEGS Improvements: Flexible MRGS (RDP-796)	49
EEGS Improvements: Clamp MPLs (RDP-798)	50
Remove Max Range Dot When In Range (RDP-800)	50
Continuous FEDS (RDP-910)	51
No-Lock Training Mode (RDP-591)	51
Remech Hands-On Missile Select (RDP-1070)	52
AIM-9L/M Bore/Slave Operations (RDP-519)	52
AIM-9 Auto Acquisition Mechanization (RDP-447)	53
Weapon Selection Not Affected By Inventory Manipulations (RDP-1503)	54
AMRAAM DLZ Changes (RDP-975); AMRAAM LOFT Cue (RDP-756)	54
AMRAAM Impact Remechanization (RDP-1238)	60
New AMRAAM Versions (RDP-645)	62
AIM-120 Active Range Indications (993)	63
AIM-120 Launch Against Marginal Track Indications (RDP-986)	64
AMRAAM Burn (RDP-964)	64
LOSE Cue In HUD Remechanization (RDP-1162)	65
SECTION 4 - AIR-TO-GROUND	67
LANTIRN Targeting Pod FLIR Interface (RDP-864)	67
Targeting Pod TV (RDP-1170)	76
Attitude Advisory Function (AAF) (RDP-1502)	76
Generic RECCE Pod II (RDP-865)	77
BAF RECCE Updates (RDP-1700)	78
New Strafe Pipper/Reticle (RDP-592)	79
Maverick Missile Launch Envelope (RDP-306)	80

TABLE OF CONTENTS (Con't)

Maverick Video Initiation (RDP-1240) 81
EO-VIS Auto SOI Sequencing (RDP-1164) 81
HARM (RDP-1200) 81
Mark-84 Transonic Algorithm (RDP-612) 98
Update CBU-87 Algorithm (RDP-625) 99

SECTION 5 - DEFENSIVE AVIONICS 101
 Selectable Threat Range Rings On The HSD (RDP-967) 101
 Report Jamming Of AIFF Frequencies (RDP-880) 101

INDEX 103

ABBREVIATIONS & ACRONYMS 109

List of Figures

Figure	Description	Page
SECTION 1 - GENERAL		
1-1	DED AACMI Mode Selection	5
1-2	Data Linked Targets Outside HSD FOV	7
1-3	MFD Horizon Line Movement during Inverted Flight	8
1-4	MFD Symbol Intensity, Brightness, And Contrast Controls	10
1-5	MFD Reset Menu Page	11
1-6	Comparison Of Reduced Symbol Size (Previous vs. Current Size)	11
1-7	DED TIME Page	12
SECTION 2 - NAVIGATION		
2-1	DTS Priority Page	14
2-2	HUD DTS Status Messages	15
2-3	HUD Obstacle Warning Indications	18
2-4	DBTC And Status HUD Cues	19
2-5	FCR AGR Page	20
2-6	Roll Stabilized DBTC Cue	21
2-7	HSD In Freeze Mode (SOI)	22
2-8	HSD In Freeze Mode (Not SOI)	22
2-9	HSD Control Page	23
2-10	NVP FLIR Base Page (Above 1,200 Feet)	24
2-11	NVP FLIR Base Page (Below 1,200 Feet)	25
2-12	HUD Landing Mode Symbology	26
2-13	ETA On HUD And DED With Valid TOS	27
2-14	ETA On HUD And DED With No Subsequent Valid TOS	28
2-15	DED UTM DIR Page	28
SECTION 3 - AIR-TO-AIR		
3-1	SCAN And LOS INTG Pages Decoupled	31
3-2	LOS INTG Page Coupled To The Active Manual Page	31
3-3	SCAN INTG Page Coupled To The Active AUTO TIM Page	32
3-4	LOS INTG Page Coupled To The Active AUTO POS Page	32
3-5	SCAN INTG Page Coupled To The Active IFF POS/TIM Pages	33
3-6	Single Mode Interrogation Selected	34
3-7	Multiple Mode Interrogation Selected	34
3-8	AIFF Interrogation Replies On The FCR Page	35
3-9	A-G DL Initialization Pages For AFAPD And TACF Protocols	36
3-10	Hands-On DL CAS IP/TGT Selection	38
3-11	CAS On Station Page	38
3-12	AFAPD CAS Mission Update Pages	39
3-13	TACFIRE CAS Mission Update Page	39

List of Figures (Con't)

Figure	Description	Page
3-14	CAS Steerpoint Destination Page	39
3-15	Continuous Mode Active/Silent	40
3-16	DED Intraflight Initialization Page	40
3-17	MFD Data Link Friendly And Unknown Symbols	41
3-18	FCR CRM/RWS SAM Mode	44
3-19	HUD Bull's-Eye Bearing And Range	45
3-20	Nose-down Inverted Attitude Awareness Arc	47
3-21	Left Climbing Bank Attitude Awareness Arc	48
3-22	Nose-down Wings Level Attitude Awareness Arc	48
3-23	Target Altitude Display In MLU HUD	49
3-24	DED Manual Page	50
3-25	Gun In-Range Indications	50
3-26	EEGS FEDS At Trigger Squeeze And Release	51
3-27	SMS Base Page	51
3-28	EEGS Level II vs. EEGS Level II No-Lock Training Mode	52
3-29	SMS Base Page	53
3-30	HUD Shoot Indication	54
3-31	AMRAAM Dynamic Launch Zone Components	55
3-32	ASEC/ASC Relationship	57
3-33	AMRAAM Dynamic Launch Zone	58
3-34	AIM-9 Missile Dynamic Launch Zones	60
3-35	MFD Target Symbology With AMRAAM Inflight	61
3-36	MFD Air-To-Air Target Symbology	61
3-37	New AMRAAM Mnemonics On The SMS Inventory Entry Page	63
3-38	AMRAAM DLZ With Active Range Indications	63
3-39	HUD AMRAAM LOSE Cue	65
SECTION 4 - AIR-TO-GROUND		
4-1	TGP OFF Page	68
4-2	TGP Base Page	69
4-3	TGP LOS Positions Relative To The Aircraft	71
4-4	TGP Control Page	72
4-5	TGP Mode Menu Page	73
4-6	Attitude Advisory For MFD Formats	77
4-7	RECCE Pod Access Via Test Button	78
4-8	HUD Strafe Pipper	79
4-9	Strafe Pipper/Reticle For M-56 And PGU-28 At Various Ranges	80
4-10	Maverick MLE in the HUD	81
4-11	High Speed Anti-Radiation Missile (HARM) (AGM-88)	81
4-12	SMS Base Page With HTV Selected	83
4-13	HARM Threat Table DED Page	84

List of Figures (Con't)

Figure	Description	Page
<hr/>		
4-14	HARM Manual Threat Pages	84
4-15	HARM Mode Menu Page	85
4-16	HARM POS WPN Delivery Page	87
4-17	HUD POS Mode Symbology	89
4-18	ALIC Video Display Before Hand-Off	90
4-19	ALIC Video Display After Hand-Off	91
4-20	HARM HAS Mode HUD Symbology	92
4-21	DED SEAD Destination Page	93
4-22	DED Steerpoint Page	94
4-23	HSD SEAD Target Display	95
4-24	Data Link SEAD Character Code Display	95
4-25	SEAD DL Page	97
4-26	SEAD Message Transmission	98
SECTION 5 - DEFENSIVE AVIONICS		
5-1	HSD Threat Ring Display	101
5-2	DED INTG Pages	102
5-3	FCR AIFF Jamming Indications	102

List of Tables

Table	Description	Page
SECTION 1 - GENERAL		
1-1	ARC-186R 8.33 KHz Frequency Channel Spacing	4
1-2	CMFD Color Palette	5
1-3	Colored Symbol Default Colors	6
1-4	Symbology And MFD Rocker Switches	9
1-5	MFD Format Types	9
SECTION 2 - NAVIGATION		
2-1	NVP Pilot Fault List	24
SECTION 3 - AIR-TO-AIR		
3-1	AMRAAM Missile ID Assignment	64
SECTION 4 - AIR-TO-GROUND		
4-1	Mark-84 CEP Improvement Percentages	98
4-2	CBU-87 CEP Improvement Percentages	99

THIS PAGE INTENTIONALLY LEFT BLANK

INTRODUCTION

Operational Flight Program (OFP) M2/M2+ is a Modular Mission Computer (MMC) based software update that will field in the late 2000 time frame. The software update is primarily a common set of new capabilities for the European Participating Air Forces (EPAF) MLU and the USAF Block 50 aircraft. However, because there are a few minor differences, the EPAF version of the software update is referred to as M2 and the USAF version is M2+. This document addresses the M2 update.

The M2 core avionics operational flight program (OFP) has incorporated numerous systems and mechanization changes that expand the current MLU aircraft tactical capability. New capabilities include Navigation and Targeting Pod Interfaces, Generic Recce II, Digital Terrain System (DTS) Phase II enhancements, Autonomous Air Combat Maneuvering Instrumentation (Autonomous ACMI), Improved Data Modem (IDM), Automatic Target Hand-off System (ATHS), and the AGM-88 High Speed Anti-Radiation Missile (HARM).

The Navigation and Targeting Pod Interfaces were integrated to support the Royal Netherlands Air Force (RNLAf) Navigation and Targeting FLIR pod procurement program. The interfaces support full Block 40T5 LANTIRN capabilities. Recce II supports a Royal Danish Air Force (RDAF) Reconnaissance Pod procurement program. It provides for operational control of Recce pod sensors and video recording equipment. DTS Phase II enhances the overall performance and accuracy of the Terrain Referenced Navigation (TRN), Obstacle Warning and Cueing (OW/C), Predictive Ground Collision Avoidance (PGCAS), and Data Base Terrain Cueing (DBTC) functions that were integrated into the Block 50/MLU MMC M1 Tape. In addition, DTS Phase II includes a Passive Ranging (PR) feature and integration of TRN with the aircraft Master Navigation Filter (MNF). Autonomous ACMI provides for in-flight recording and storage of F-16 mux bus data that will be used for mission de-briefing. The IDM ATHS provides the ability to transmit an "On-station" message and receive a "Mission Update (CAS 9-line brief)" via the IDM. The AGM-88 HARM is an air-to-surface missile designed to suppress RF (Radio Frequency)-based enemy air defenses.

The M2 OFP also includes significant enhancements to the Hands-on control functions, Color Multifunction Display (CMFD) symbology, Horizontal Situation Display (HSD) format, Advanced Identification Friend or Foe (AIFF), and Head-up Display (HUD) symbology. Many of these enhancements resulted from pilot feedback during the M1 flight testing activities.

The purpose of this guide is to facilitate a basic understanding of the capabilities and cockpit mechanizations in the M2 software update. To keep the contents of the document short and concise, previous knowledge of the MLU cockpit operation is assumed. Each capability and cockpit mechanization is identified with a title and an RDP number. The RDPs (Requirements Definition Packages) are maintained by Lockheed Martin Aeronautics Company (LM Aero) and contain detailed design requirements for each capability. If additional details are required concerning a particular capability consult 16PR13133, F-16 Avionics Systems Manual (MLU M2), T.O. 1F-16AM-34-1-1, Avionics and Non-Nuclear Weapons Delivery Flight Manual, or contact LM Aero Pilot Vehicle Interface at 817-777-8732.

THIS PAGE INTENTIONALLY LEFT BLANK

SECTION 1 - GENERAL

This section discusses the following topics:

- Core Avionics Provisions
- Avionics Selection After MMC Power Cycle
- Jettison Delay For 600 Gallon Tanks
- AN/ARC-186R VHF Radio 8.33 kHz Channel Spacing
- Autonomous ACMI
- Color Display Optimization
- Color Data Linked Information Outside The HSD FOV
- MFDS Horizon Line Incorrect When Inverted
- MFD Contrast/Brightness Control
- MFD Display Gain Control Option Incorporation
- Reduce Size Of FCR Symbology
- GPS Time Available On BUS/GPS Time Use

Core Avionics Provisions (RDP-052)

M2 incorporates changes resulting from the USAF Block 50T5 baseline software. It updates the Multiplexed (MUX) duty cycle and incorporates flight test generated System Problem Anomaly Reports (SPARs) that have been resolved.

Avionics Selection After MMC Power Cycle (RDP-1367)

All avionics and weapon selections should come up “last left” after an airborne MMC power cycle (auto restart, manual MMC power cycle, or aircraft power cycle). All avionics selections should come up “last left” and weapon power selections should be “Off” (AIM-9 WARM, AGM-65 POWER OFF, PENGUIN POWER OFF) after an MMC power cycle on the ground.

Jettison Delay For 600 Gallon Tanks (RDP-2000)

Stores weight and drag values for the 370 and 600 gallon tanks have been corrected. Additionally, a 150-ms delay has been implemented in the jettison of the 600-gallon tanks to reduce the potential of tank-to-tank collision after being jettisoned.

AN/ARC-186R VHF Radio 8.33 kHz Channel Spacing (RDP-1701)

The Very High Frequency (VHF) Amplitude Modulation (AM) radio channel bandwidths have been decreased from 25-kHz to 8.33-kHz (5-kHz pseudo-channels) to support the International Civil Aviation Organization’s (ICAO’s) effort to reduce VHF frequency saturation in Europe. The bandwidth reduction provides two additional channels between the original 25-kHz band spacing as shown in columns 1 and 2 of Table 1-1. To accommodate the reduced channel spacing, the 1553 Mux bus terminal interface, the Communication, Navigation and IFF (CNI) Data Entry Display (DED) and COMM 2 DED pages have been modified (a thousandths digit added) to support DTC and manual loading of the 8.33-kHz channels. To specify the desired

VHF frequency on the modified radio, the pilot is required to enter 5 or 6 digits, as shown in column 3 of Table 1.1. Six digits are required for channels ending in 5 (e.g., 108.005) and five digits for channels ending in 0 (e.g., 108.030).

The functionality and operation of the VHF Frequency Modulation (FM) frequency bandwidth (30 – 88 MHz) was not changed by the radio modifications.

Table 1-1 ARC-186R 8.33 KHz Frequency Channel Spacing

25kHz Mode	FREQUENCY (MHz)	8.33 kHz Mode
108.000	108.00000	108.005
	108.00833	108.010
	108.01667	108.015
108.025	108.02500	108.030
	108.03333	108.035
	108.04167	108.040
108.050	108.05000	108.055
	108.05833	108.060
	108.06667	108.065
108.075	108.07500	108.080
	108.08333	108.085
	108.09167	108.090
108.100	108.10000	108.105

Autonomous ACMI (RDP-867)

Autonomous Air Combat Maneuvering Instrumentation (AACMI) provides data for post flight mission debriefs for training and maintaining aircrew tactical warfare proficiency. The AACMI data consists of the current Enhanced ACMI (EACMI) data and RADA flight Fatigue/Air Combat Evaluator (FACE) data. The data is sent to a dedicated terminal address on the MUX bus for data recording by country specific passive monitor recording devices. Different European Participating Air Forces (EPAF) may choose to monitor data via different means.

AACMI data recording is selectable via the Up-Front Controls (UFC) (Figure 1-1). Depress LIST → FIX-8; depress the Data Control Switch (DCS) down to place the asterisks around “*AACMI RECORD*”; and depress Mode-Select [M-SEL]. “AACMI RECORD” is highlighted when selected. No further pilot interaction is required. AACMI Record defaults to disabled after a MMC OFP load or ground power cycle. It maintains its current status during a MMC power cycle in the air.

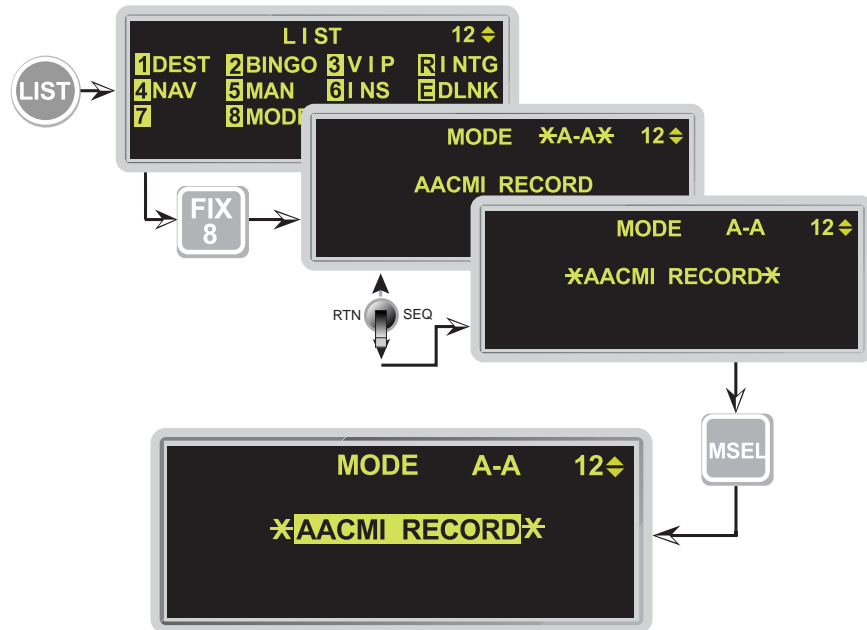

Figure 1-1 DED AACMI Mode Selection

Color Display Optimization (RDP-1054)

In order to provide Night Vision Imaging System (NVIS) compatible Color Multi-Function Displays (CMFD), two separate backlights are used. Together the two backlights generate the full luminance range (0.04-190 ft-lamberts). The transition between the two lamps is controlled internal to the CMFD. In the NVIS mode the day lamp is disabled, which forces the CMFD to use only the night (NVIS compatible) lamp. There is a slight color shift (less red) when only the night lamp is used.

Table 1-2 CMFD Color Palette

White	
Red	
Green	
Cyan	
Yellow	
Magenta	
Blue	
Gray	

The CMFD color palette is fixed and defined by the 8 colors listed in Table 1-2. (Colors in the table and illustrations of this book only approximate the actual display colors.) The color palette consists of the primary subtractive colors and the primary additive colors plus white and gray.

The pilot has the ability to change the color of symbols via the Data Transfer Cartridge Loader/Reader (DTC L/R) during mission planning. Color changes are loaded into the CMFD by depressing COLR (OSB #2) on the DTE page. Once loaded into the aircraft, the new color table is retained through MFD power cycles until a subsequent DTC load changes the color table.

The default colors for the Rules Of Engagement (ROE) dependent color symbols are listed in (Table 1-3).

Table 1-3 Colored Symbol Default Colors

D/L Team Member		Cyan
D/L Friendly		Green
D/L Unknown		Yellow
D/L Team Member Outside FOV		Cyan
D/L Unknown Outside FOV		Yellow
Unknown System Track Target		Yellow
Unknown System Track Target (w/ AIM-120)		Magenta
Unknown System Track Target (w/ Active AIM-120)		Red
Nav Route		Gray
Active Nav Route		White
GEO Lines (1-4)		Gray
Preplanned Threat		Yellow
Preplanned Threat (w/ Ownship in Lethal Range)		Red

Color Data Linked Information Outside The HSD FOV (RDP-884)

When Data Link (DL) team members fall outside the Horizontal Situation Display (HSD) Field Of View (FOV), they are represented by a cyan filled triangle at azimuth on the outer range ring of the HSD (Figure 1-2). The team member's number is displayed above the triangle. If the team member has a Target Of Interest (TOI) outside the HSD FOV, it is displayed as a filled yellow triangle at azimuth on the outer range ring with the team member number above it to distinguish which team member has bugged that target.

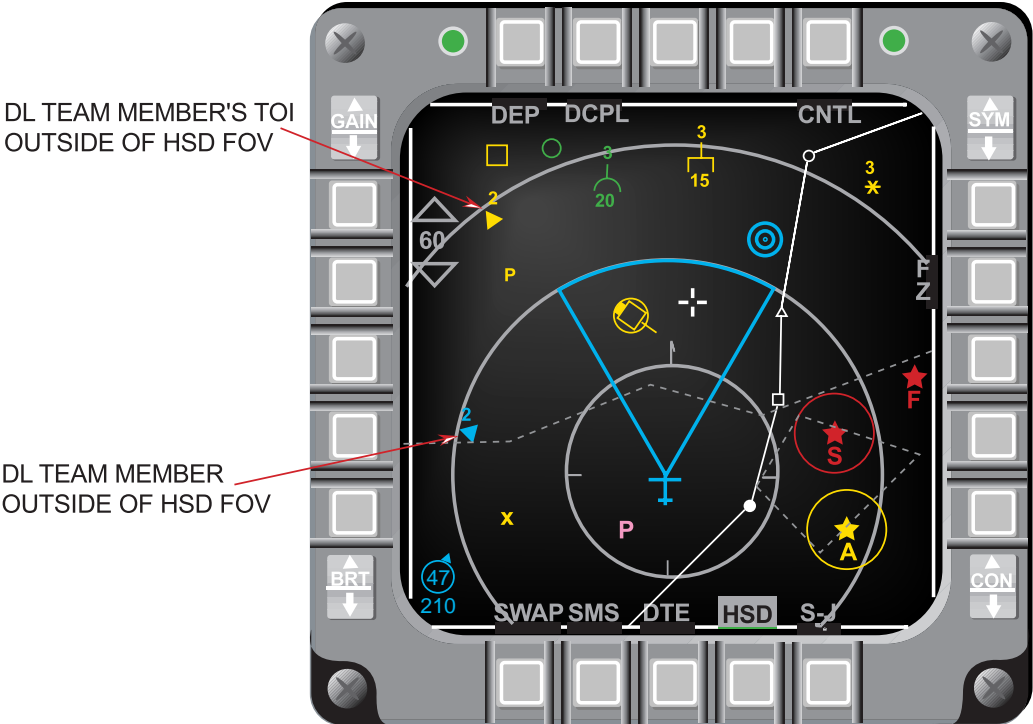

Figure 1-2 Data Linked Targets Outside HSD FOV

MFD Horizon Line Incorrect When Inverted (RDP-1246)

The Horizon line operation displayed on the Multi-Function Display (MFD) formats has been modified such that when the aircraft is flying inverted and pitching toward the ground, the horizon line on the MFD moves toward the bottom of the MFD display (Figure 1-3). The horizon line now indicates the true direction to the horizon.

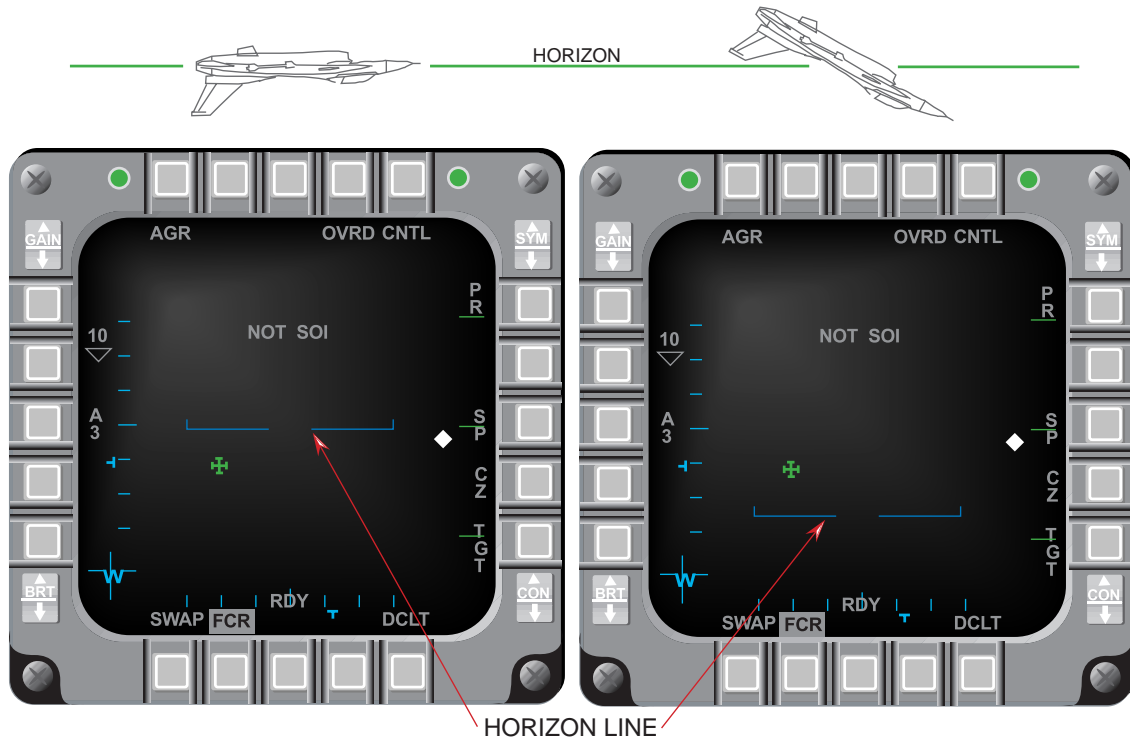

Figure 1-3 MFD Horizon Line Movement during Inverted Flight

MFD Contrast/Brightness Control (RDP-1160)

When swapping MFD formats (OSB #15) in either the forward or aft station, brightness and contrast settings are retained per format when transitioning to the new display. Symbol intensity is saved on a per channel basis per format such that symbol intensity changes made to the aft left display will affect the forward left display. The same holds true for the right displays.

Three unique display types are used on the MFDs: text, video, and symbols. The MFD rocker switches that affect text, video and symbols as defined in Table 1-4.

Table 1-4 Symbology And MFD Rocker Switches

Things You See on an MFD	MFD Rocker Switches		
	BRT	CON	SYM
TEXT	X	X	X
VIDEO	X	X	NA
MFD Generated Symbols	X	X	X
Video Generated Symbols	X	X	X(See Note)

NOTE:

MFD Symbol Intensity affects TGP and Fire Control Radar (FCR) Video via M1 documentation. The M1 baseline provides for feedback of MFD symbol intensity to the FCR and to the TGP in an effort to match symbol intensity of the MFD generated symbology with that of the FCR and TGP symbology.

Table 1-5 divides the formats into Video and Non-Video displays:

Table 1-5 MFD Format Types

VIDEO FORMATS	NON-VIDEO FORMATS
FCR	HSD
TGP	SMS
FLIR	TEST
RCCE	DTE
WPN	FLCS
TFR	BLANK

Symbol Intensity, Brightness and Contrast (SBC) values for each Format (Figure 1-4) are saved as follows:

- 1) One symbol intensity value is saved for all MFD symbols which appear for all non-video formats
- 2) A different symbol intensity value is saved for each video format
- 3) One brightness value is saved for all non-video formats
- 4) A different brightness value is saved for each video format
- 5) One contrast value is saved for all non-video formats
- 6) A different contrast value is saved for each video format

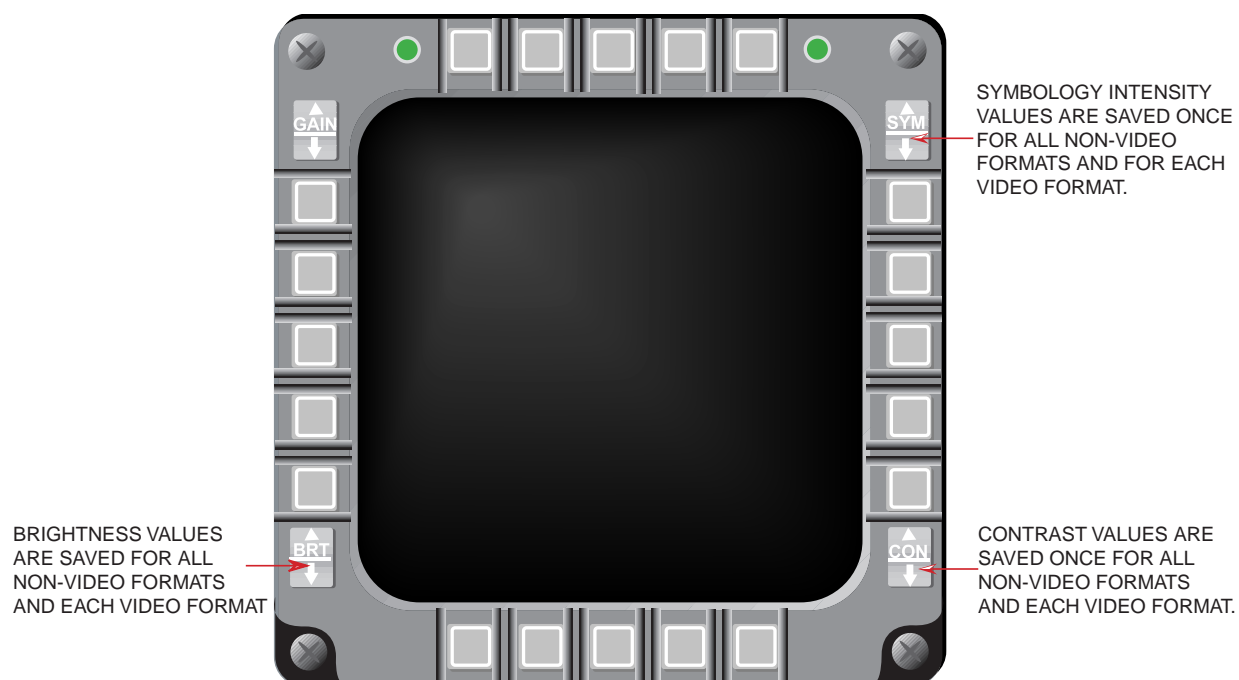

Figure 1-4 MFD Symbol Intensity, Brightness, And Contrast Controls

MFD Display Gain Control Option Incorporation (RDP-1703)

Test and laboratory analysis has shown that MFD display quality can be improved during low ambient light conditions (night-time operation) by disabling the Display Gain Control (DGC). This candidate adds a display gain control feature to the MFD Reset Menu page as shown in Figure 1-5. The DGC is initialized to OFF at MFDS power-up. Depressing OSB #2 (DGC) toggles the display gain control between ON and OFF for all applicable formats.

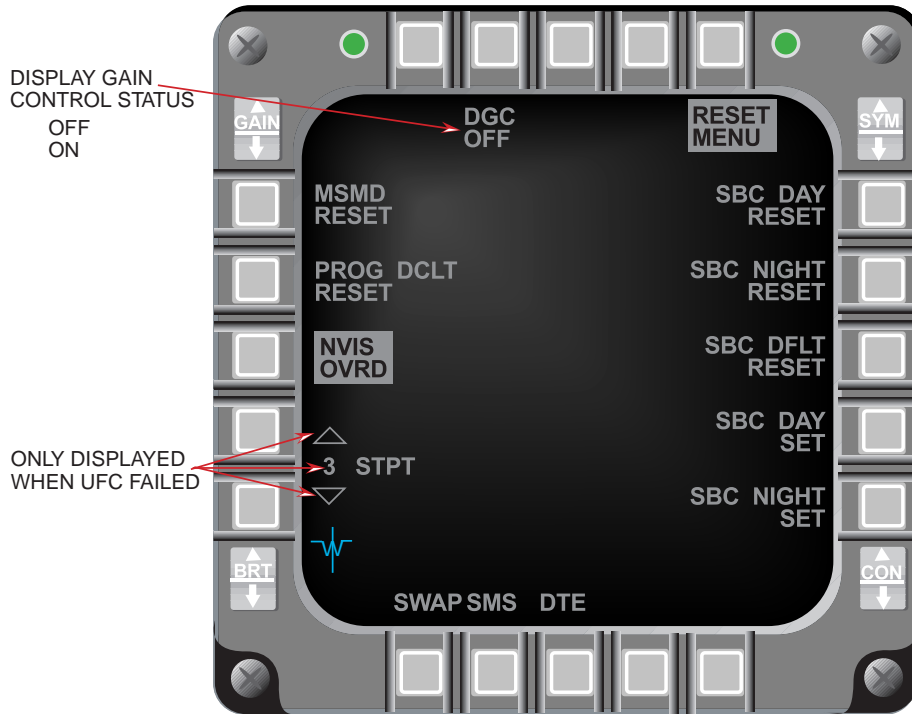

Figure 1-5 MFD Reset Menu Page

Reduced Size Of FCR Symbology (RDP-925)

Radar system track targets (including the bugged target), and data linked targets (Friendly and Unknown) are reduced to 75% of their previous size (Figure 1-6). These symbols are reduced on the FCR and HSD displays.

100%	75%		100%	75%	
		System Track			DL Friendly
		Bugged Target			DL Unknown

Figure 1-6 Comparison Of Reduced Symbol Size (Previous vs. Current Size)

GPS Time Available On Bus/GPS Time Use (RDP-1159)

The pilot has the option to select/deselect Global Positioning System (GPS) time as system time when GPS time is available. The GPS label adjacent to the system time on the DED Time page (Figure 1-7) indicates that GPS time is the source of system time. The source of system time initializes to GPS at power-up on the ground. The GPS label will not appear until the GPS time is valid. GPS time is deselected by depressing the DCS to sequence (SEQ) with GPS time selected. When GPS time is deselected, GPS is turned off, or GPS time becomes invalid, the GPS label is blanked and system time can be entered on the TIME or CRUS TOS page. When time is entered on the CRUS TOS page, GPS time is deselected.

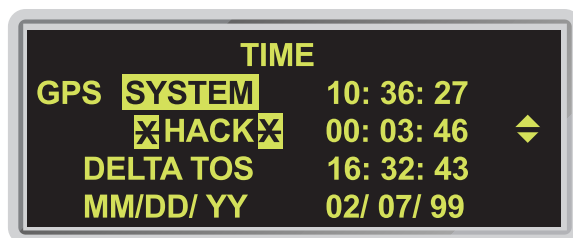

Figure 1-7 DED TIME Page

The current month, day , and year have been added to the TIME page.

SECTION 2 - NAVIGATION

This section introduces the following Navigation enhancements:

- Digital Terrain System (DTS) Phase II
- DBTC Whiskers
- Roll Stabilized DTS DBTC Cue
- HSD Freeze Enhancements
- HSD Declutter By Master Mode
- Identify The Active Navigation Route
- NVP Boresight And Faults
- NVP Laser Spot Locator (LSL)
- Include Current Master Mode In DTE Load
- Hands-On Declutter Of HUD Symbology (Landing Phase)
- Time-Over-Steerpoint (TOS) Refinements
- UTM Coordinate Entry Of Up To Four Digits

Digital Terrain System (DTS) Phase II (RDP-1077)

The Digital Terrain System (DTS) Phase II development and the Block 50T5 DTS flight test activities have been combined to significantly improve the overall DTS performance found in the M1 OFP. DTS Phase II adds a Passive Ranging (PR) feature and improves the Terrain Reference Navigation (TRN) aircraft position accuracy which, in-turn enhances the performance of Predictive Ground Collision Avoidance System (PGCAS), Obstacle Warning and Cueing (OW/C), and Data Base Terrain Cueing (DBTC) functions. Additional mechanization revisions and features have been incorporated at M2 to increase the operational utility of DTS functions. The changes from M1 DTS capabilities are addressed below.

Terrain Reference Navigation (TRN) Enhancements:

- 1) Expanded Area of Operation: The DTS area of operation has been increased from 75 degrees North and South latitude to 80 degrees North and South latitude.
- 2) TRN Integrated with Master Navigation Filter (MNF): The TRN function has been integrated with the MNF. TRN data is used as inputs to the MNF when GPS data fails to meet MNF processing criteria and the MNF co-variances indicate that TRN is providing more accurate data than GPS.
- 3) Blanking TRN Horizontal and Vertical Confidences: When TRN is in Acquisition, the TRN Horizontal and Vertical Confidences on the DED DTS Priority page (Figure 2-1) are blanked. In M1, the TRN Horizontal and Vertical Confidences were displayed when TRN was in Acquisition.

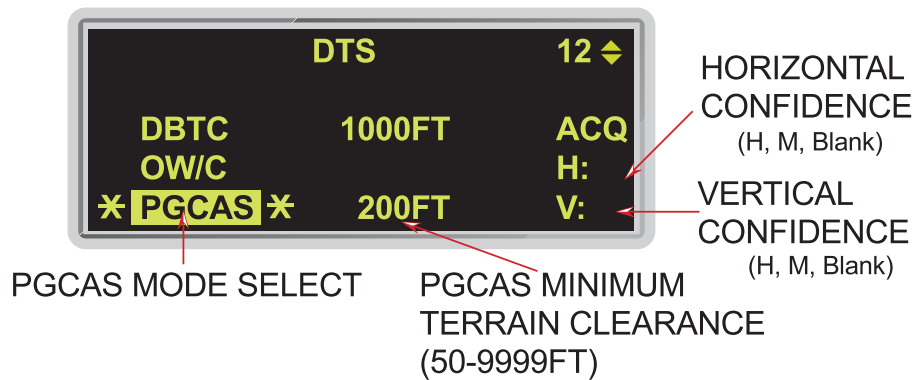

Figure 2-1 DTS Priority Page

- 4) Filter Mode Expanded on DED NAV Commands Page: The master navigation filter mode on the NAV Commands page has been expanded to include DTS. In M1, the AUTO filter mode provided automatic processing of GPS, INS data, and manual fixes for deriving the aircraft system navigation solution. In M2, the DTS navigation solution replaces the system navigation solution (whole value replacement) when GPS data is not available. The filter mode selection rotary (AUTO, INS, Blank) is unchanged.
- 5) DTS Status Changes: PVI for the display of "DTSFIX" and "NO GPW" on the HUD (Figure 2-2) has been changed. First, the "DTSFIX" mnemonic has been changed to "DTSACQ." "DTSACQ" flashes in the HUD above the airspeed scale, instead of top-center HUD, when TRN is in Acquisition Mode and PGCAS is not selected. If the PGCAS function is selected before TRN goes into Acquisition mode, a flashing "NO GPW" is displayed instead of "DTSACQ". Depressing Warn Reset changes the flashing "DTSACQ" or "NO GPW" mnemonic to a steady condition. Neither "DTSACQ" nor "NO GPW" is displayed when the INS is doing an In-Flight Alignment (IFA).

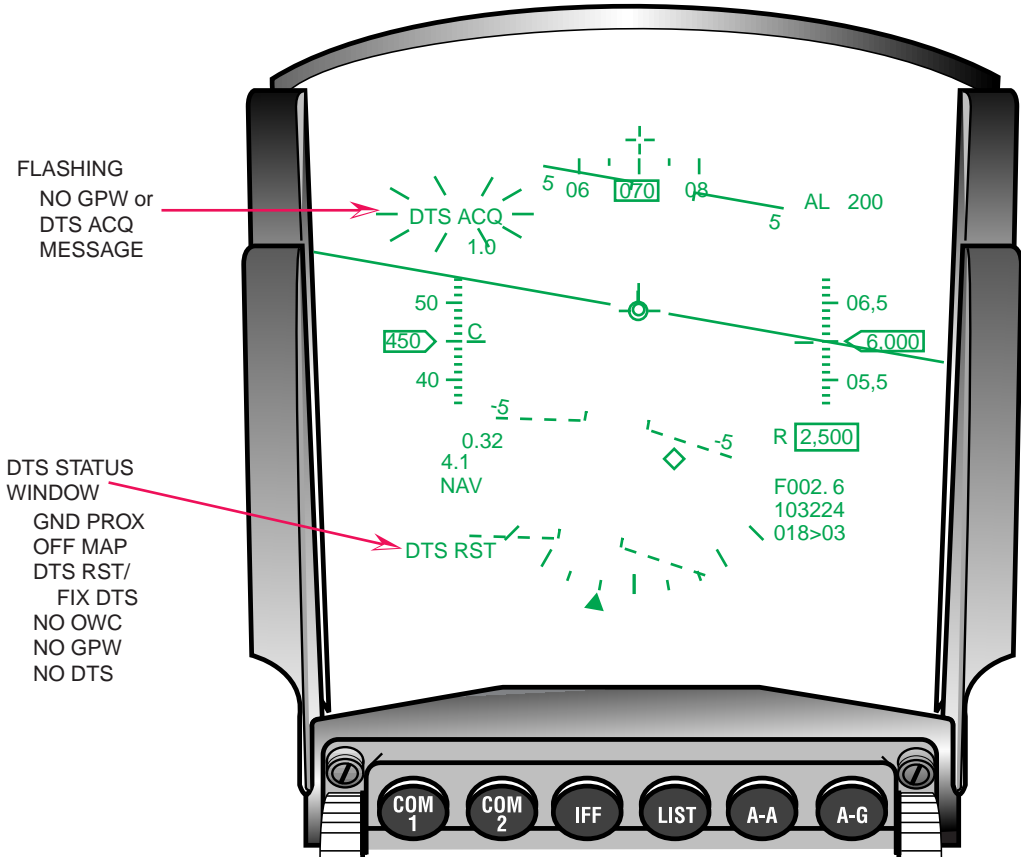

Figure 2-2 HUD DTS Status Messages

Additional mnemonics are displayed in the lower left portion of the HUD to provide expanded information concerning the "DTSACQ" or "NO GPW" messages. For example, if the aircraft position exceeds the boundaries of the DTS Digital Flight Map (DFM), TRN goes into Acquisition mode, "DTSACQ" (or "NO GPW", if PGCAS has been selected) appears at the top left portion of the HUD, and the "OFF MAP" message is displayed in the lower left portion of the HUD. The pilot has to fly the aircraft back over the DFM to return the TRN function to the track mode.

When TRN enters Acquisition, the MNF immediately provides TRN with a position update (fix). If TRN rejects the MNF fix, a DTS Reset ("DTS RST") message is displayed to advise the pilot of the rejected fix. Lifting and resetting the handle on the DTS Data Transfer Cartridge (DTS/DTC) resets the TRN function. A DTS Fix ("FIX DTS") mnemonic is displayed if the MNF fix was not sent to the TRN function. In this case, the pilot would perform a normal navigation position update to help TRN enter track mode.

If PGCAS is selected and TRN goes into the Acquisition mode, a flashing No Ground Proximity Warning ("NO GPW") mnemonic is displayed above the airspeed scale of the HUD instead of a flashing "DTSACQ." Mnemonics, in the lower left-hand corner of the HUD, provide the status information discussed above (DTS RST, FIX DTS, OFF MAP). Four additional mnemonics may appear in this HUD window. The first three mnemonics (1-3) discussed below require the TRN function to be operating in track mode:

- 1) "GND PROX" is displayed when PGCAS has triggered a "Break X" on the HUD and the MFDs to warn of imminent ground collision.
- 2) "NO OWC" indicates that the DTS obstacle warning and cueing feature is not functional. The "NO OWC" message is inhibited for 30 seconds after the landing gear is up.
- 3) "NO GPW" is displayed when TRN is in track and PGCAS is not selected.
- 4) "NO DTS" indicates the Digital Terrain System is not functional.

NOTE:

Failure to lock the DTS/DTC in the data transfer unit will cause a "NO DTS" message.

Expanded messages in the lower left portion of the HUD are displayed in the following prioritized order: "GND PROX", "OFF MAP", "DTS RST", "FIX DTS", "NO OWC", "NO GPW", and "NO DTS".

Vertical Velocity Propagator (VVP):

The Vertical Velocity Propagator (VVP) feature calibrates the INS estimate of aircraft vertical velocity with either DTS or GPS vertical velocity data. The VVP provides enhanced inputs for aircraft algorithms requiring accurate vertical data. The feature is automatically enabled when the Auto ACAL is selected for operation.

Predictive Ground Collision Avoidance System (PGCAS):

The following changes were added to improve the PGCAS functions operational utility:

- 1) Expanded Operational Limits: Maximum calibrated airspeed limit was increased from 640-KCAS to 800-KCAS for the PGCAS function.
- 2) PGCAS Minimum Terrain Clearance (MTC) Reset: When DBTC is selected, the PGCAS MTC altitude is automatically set based on the selected DBTC Terrain Clearance Height (TCH), otherwise, the PGCAS algorithm uses the selected MTC altitude entered on the DTS Priority page. When DBTC has been selected and is subsequently de-selected, the PGCAS algorithm continues to use the MTC altitude defined by the DBTC TCH selection until the aircraft climbs above the TCH based altitude. Once the MTC altitude has been exceeded, the MTC will reset to the altitude selection on the DTS Priority page. In M1, the MTC was immediately reset to the selection on the PGCAS page when DBTC was deselected.
- 3) Revised PGCAS MTC Altitudes: MTC altitudes were modified for M2. The MTC is set to 25 percent of the ALOW or 50 feet, whichever is greater. If ALOW is set to zero, the MTC is set to 250 feet. MTC entries made on the DTS Priority page override the ALOW-based MTC. The MTC remains at its last-left value during in-flight MMC power cycles. MMC power cycles on the ground reset the MTC to the ALOW-based value.
- 4) Automatic Fifty-Foot MTC: In M2, the 50-foot MTC setting is automatically selected when the A-G weapon delivery mode is CCIP or Strafe. The

PGCAS predicted recovery curve for M2 was changed to a 5-G pull-up instead of the M1 4-G pull-up and the MFDS Break X display was changed to 1.1 seconds time-to-go to pull-up for M2 instead of 2 seconds in M1. These changes were made to reduce the number of nuisance warnings.

PGCAS advisories are affected by the accuracy of the DFM loaded into the DTS/DTC. A 50 feet MTC entry does not guarantee that PGCAS provides adequate protection to a 50 feet MTC for any particular mission. PGCAS advisories are also based on the current stores loading and if the wrong stores and/or store quantities, or a manual fuel transfer is accomplished causing an asymmetrical fuel loading, PGCAS effectiveness may be impacted.

Obstacle Warning and Cueing (OW/C):

OW/C is initialized to the enabled state and may be disabled/enabled on the DTS Priority page. OW/C provides a warning whenever a significant obstacle is detected in the OW/C scan area near the predicted flight path of the aircraft. A significant obstacle is one where the obstacle height plus the clearance height is greater than the projected flight path of the aircraft. A flashing "OBSTACLE" is displayed in the top, center of the HUD (Figure 2-3) to warn the pilot of any significant obstacles. M2 modified the obstacle clearance height to be 75% of the DBTC TCH during DBTC operation. When DBTC is not selected, a default value of 500 feet is used.

For aircraft bank angles greater than 90 degrees, OW/C advisories are not valid even though they are displayed. The pilot should visually verify adequate clearance to avoid towers and their associated guy wires.

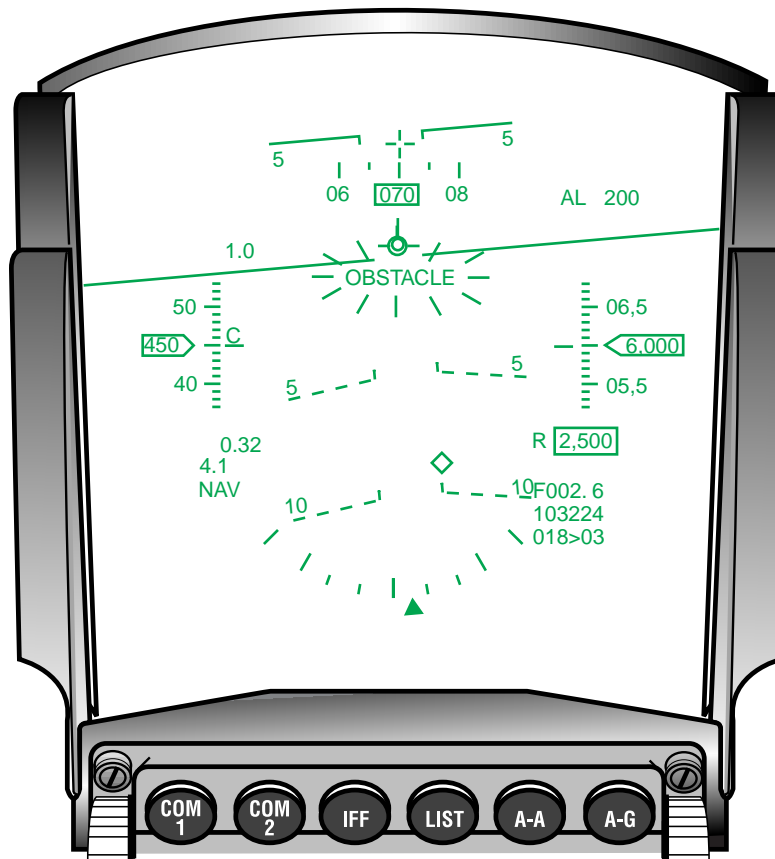

Figure 2-3 HUD Obstacle Warning Indications

Database Terrain Cueing (DBTC):

The DBTC algorithm in the Digital Terrain System Application Software (DTSAS) was modified to improve performance. In response to M1 and Block 50T5 flight test feedback, the DBTC mechanization has undergone the following changes:

- 1) Revised Range Of Pilot Selectable TCH Values: In M1, TCH was set via a rotary of predefined values (1000 ft., 500 ft., 300 ft., 200 ft., and 100 ft.) on the DTS Priority page. In M2, TCH is set to 100% of the ALOW setting or 100 feet, whichever is greater. However, if ALOW is set to zero, TCH defaults to 1000 feet. The pilot may manually override the ALOW-based TCH via the DTS Priority page and set any value from 100 ft. to 9,999 ft. The TCH retains its last-left value during in-flight MMC power cycles. MMC power cycles on the ground, reset the TCH to the ALOW-based value. Once the ALOW-based TCH is overridden, the TCH must be changed on the DTS Priority page.
- 2) DBTC HUD Enhancements: M1 used a space-stabilized box as the HUD DBTC cue. This cue suggests that the FPM has to be kept within the box to achieve certain flight/terrain clearance parameters. The DBTC cue is intended to provide reference information rather than guidance informa-

tion. As a result, M2 changed the DBTC steering cue to a set of chevrons, or "whiskers" spaced 30-mr apart (See RDP-1510), with the longest "whiskers" indicating up (Figure 2-4). The steering cue moves vertically with respect to the Flight Path Marker (FPM) to indicate a climb or descent to maintain the selected TCH. The steering cue is roll-stabilized (no longer blanked when exceeding 120 degrees of bank) on the HUD (See RDP-1244) and positioned based on a maximum -0.9-G pushover or 2.0-G incremental pull-up maneuver. A TCH caret is positioned on the HUD altitude scale when the TCH is within the displayed scale. When the Barometric (BARO) scale is displayed, the TCH AGL caret is adjusted to reflect the equivalent BARO altitude.

The DBTC low terrain clearance ("LO TC") advisory is displayed in the center of the HUD FOV when radar altitude is below 75% of the selected TCH. The DBTC cue and "LO TC" advisory are blanked when either the total INS velocity or the calibrated airspeed is less than 300 knots.

DBTC is limited to 640 knots unlike other DTS functions that are cleared to 800 knots.

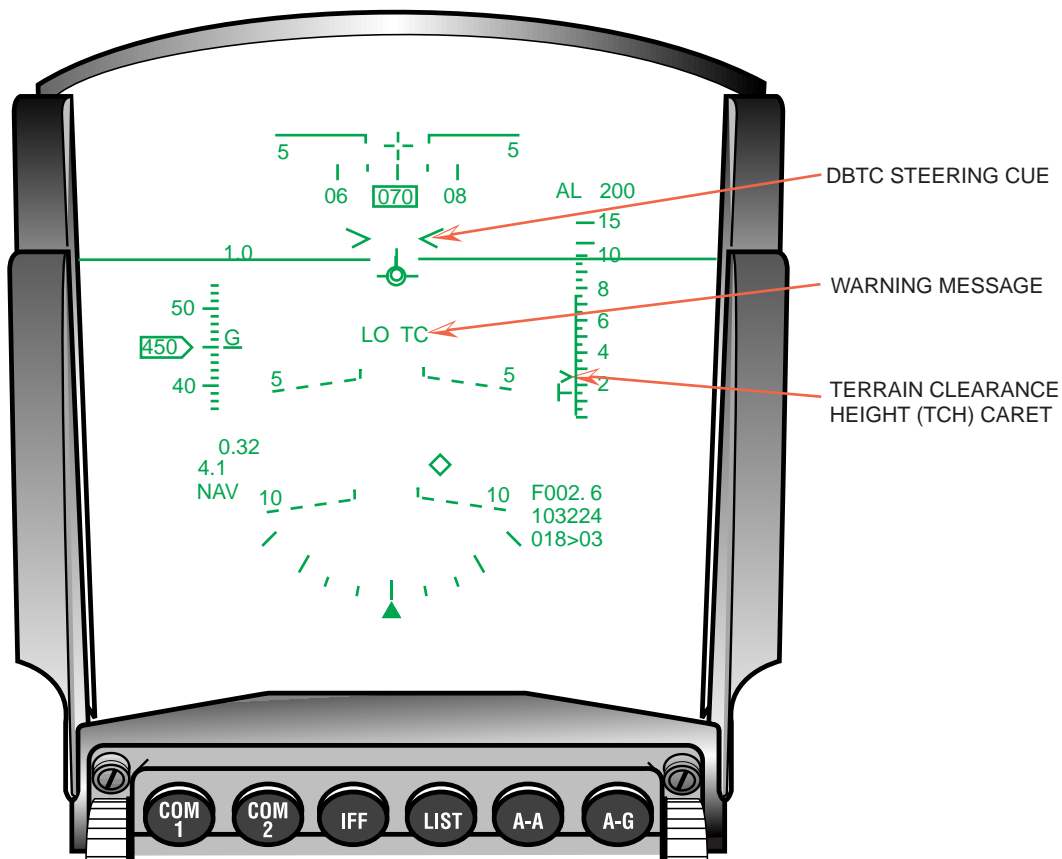

Figure 2-4 DBTC And Status HUD Cues

Note:

The digital terrain elevation and obstacle databases do not account for foliage.

Passive Ranging:

The Passive Ranging (PR) function is a new M2 DTS capability that provides the pilot with a back-up bombing sensor option to determine the range to a ground target with little or no RF emissions. Passive Ranging has two submodes with the appropriate submode automatically commanded by the avionics system based on the current Air-to-Ground (A-G) weapon delivery mode. Horizontal Range Known (HR) is used in the A-G preplanned modes (CCRP, LADD, EO-PRE). HR requires the avionics system to pass the target horizontal range X and Y to the DTS, which then returns the target elevation. The avionics system uses target elevation to determine the Height Above Target (HAT) and then slant range. The other submode, LOS Known, is used for the visual A-G deliveries modes (CCIP, DTOS, EO-VIS) which normally use AGR for ranging data. The target LOS is sent to the DTS which uses target elevation, range X, Y, and Z, plus target latitude and longitude to compute slant range.

Passive Ranging is selected on the FCR AGR page (OSB #6). The Backup Bombing Sensor (BBS) rotary (Figure 2-5) is BARO, PR, and RALT. BBS defaults to BARO on power-up. When DTS/DTC is not operational, the system reverts to BARO and removes PR from the BBS rotary. The pilot may select RALT, provided the radar altimeter is operational. When PR is the selected option and the DTS/DTC is no longer operational, BBS changes to BARO.

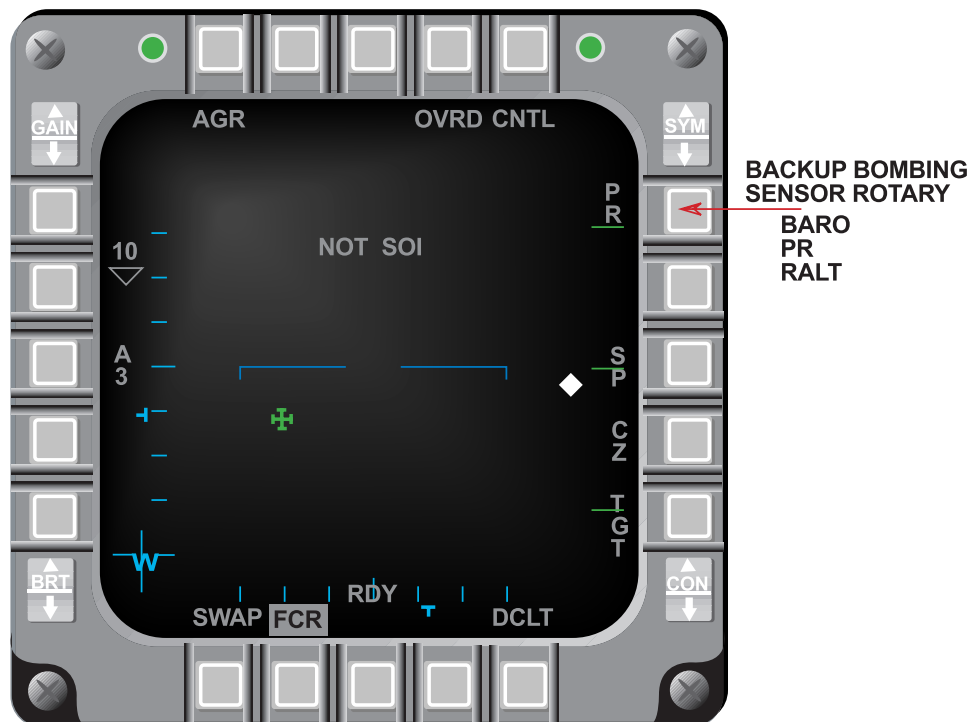

Figure 2-5 FCR AGR Page

PR is limited to a 10-km (5.4-nm) range because of the manner in which the DTS scans the DFM stored in the DTS/DTC. PR is not available when:

- 1) TRN is in ACQ mode.

- 2) The aircraft total inertial velocity is above 800 KCAS.
- 3) DTS status is "NO DTS" or "OFF MAP".
- 4) The aircraft approaches the edge of the DFM and sufficient digital data is not available to support PR.

DBTC Whiskers (RDP-1510)

DBTC uses the Digital Terrain Elevation Data (DTED), obstacle database stored in the DTS/DTC and aircraft state to provide a vertical steering cue on the HUD. The vertical steering cue, "Whiskers", (> <) assists in flying a smooth, well-damped trajectory over accurately registered terrain and obstacles.

Roll Stabilized DTS DBTC Cue (RDP-1244)

The DTS DBTC cue is roll stabilized on the HUD (Figure 2-6) and is displayed at all bank angles.

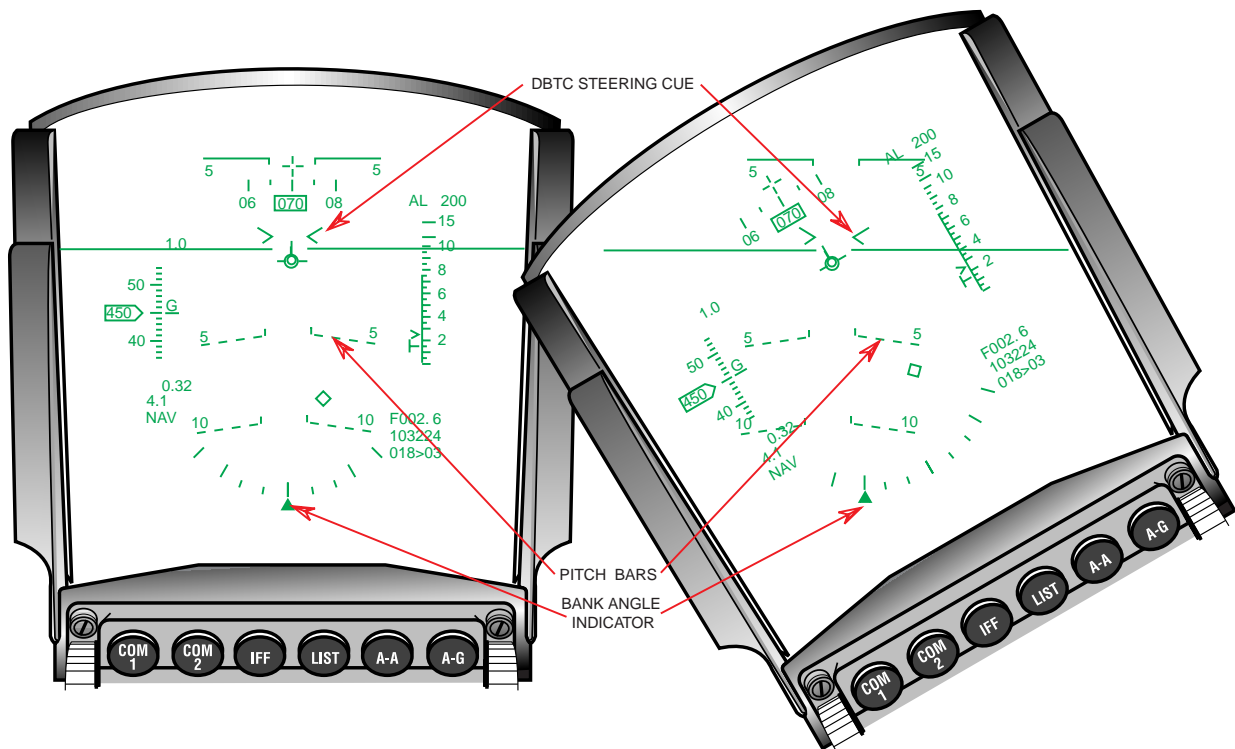

Figure 2-6 Roll Stabilized DBTC Cue

HSD Freeze Enhancements (RDP-1053)

When the Horizontal Situation Display (HSD) is selected as the Sensor of Interest (SOI), Depress and Release (D&R) OSB #7 (Freeze (FZ)) on the HSD Base page, freezes the HSD about the cursor position. Upon entering freeze, the HSD utilizes the centered format to ground stabilize about the cursor position at the center of the display (Figure 2-7).

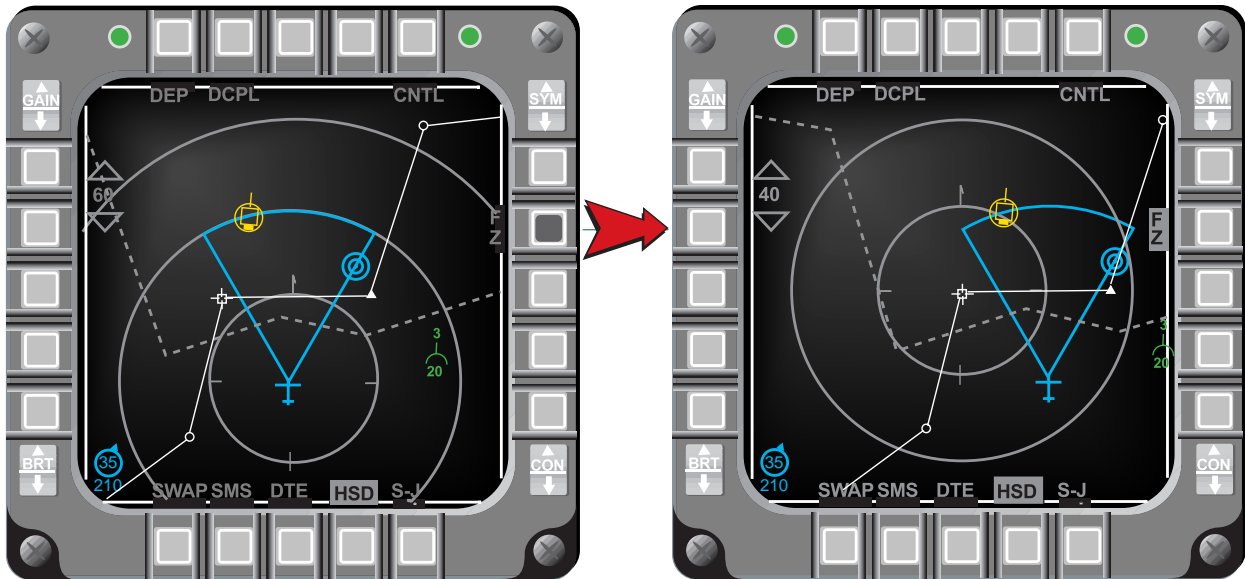

Figure 2-7 HSD In Freeze Mode (SOI)

When the HSD is not the SOI, D&R of FZ (OSB #7) freezes the HSD about the ownship position (Figure 2-8). Upon entering freeze, the HSD utilizes the centered format to ground-stabilize the instantaneous ownship position at the center of the display.

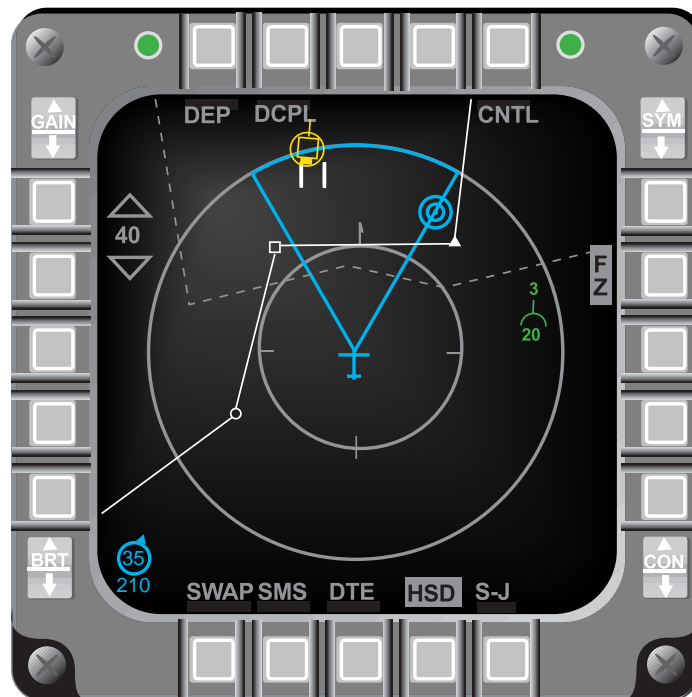

Figure 2-8 HSD In Freeze Mode (Not SOI)

While the HSD is in Freeze, data in steerpoints 1-99 are frozen; expand and couple/decouple are disabled. The ownship symbol and accompanying radar field-of-view move on the frozen map. The aircraft symbol can be flown off the frozen map or can disappear due to different range scales selected with respect to the ground-stabilized center of the display format. HSD cursors, if available, can also be slewed on the map to control the Bump Range capability.

Range rings and the magnetic North pointer are displayed in Freeze if selected on the HSD Control page. When in Freeze, if the range rings and magnetic North pointer are not displayed, RINGS (OSB #10) may be selected for display via the Control page. Upon exiting HSD Freeze, the range rings and magnetic North pointer will continue to be displayed. If the HSD was in the depressed format before entering Freeze, upon exiting Freeze, the HSD changes back to the depressed format and the range scale changes back to the corresponding range.

The Increment/Decrement (INC/DEC) Range symbols are displayed in HSD Freeze page at OSBs #19 and #20. D&R of OSB #19 decreases the range scale by one setting. D&R of OSB #20 increases the range scale by one setting. Bump Range is available in Freeze only when the HSD is the SOI (HSD cursors are displayed). When Freeze is entered and the HSD is not the SOI, the HSD can be selected as the SOI and the HSD cursors will initialize in the center of the display format.

HSD Declutter By Master Mode (RDP-972)

The pilot has the ability to set HSD Control page options (Figure 2-9) for each master mode during mission planning and load them into the aircraft via the Data Transfer Equipment (DTE). When the pilot sets the display parameters on the HSD Control page in the aircraft, these parameters are retained as last left upon reentering the master mode in which they were set. Any items, which are decluttered on the HSD Control page, are saved by master mode.

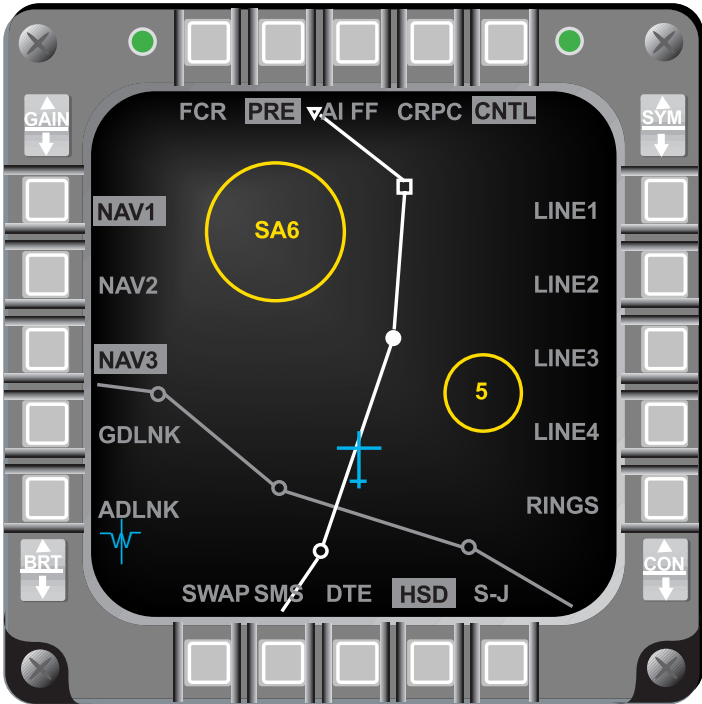

Figure 2-9 HSD Control Page

Identify The Active Navigation Route (RDP-1002)

The active Navigation (NAV) route is defined as the NAV route containing the currently selected steerpoint. Separate colors/intensities can be loaded for the active NAV route and the inactive NAV routes separately. White is the default for the active NAV route and gray is the default for the inactive NAV routes (Figure 2-9).

NVP Boresight And Faults (RDP-1169)

The FLIR Boresight (BSGT) OSB #10 on the FLIR Base page (Figure 2-10) allows selection/deselection of the Navigation Pod (NVP) boresight mode. The mnemonic “BSGT” is highlighted when the boresight mode is selected. When “BSGT” is selected, cursor slews are passed to the NVP to adjust the FLIR video to the outside world.

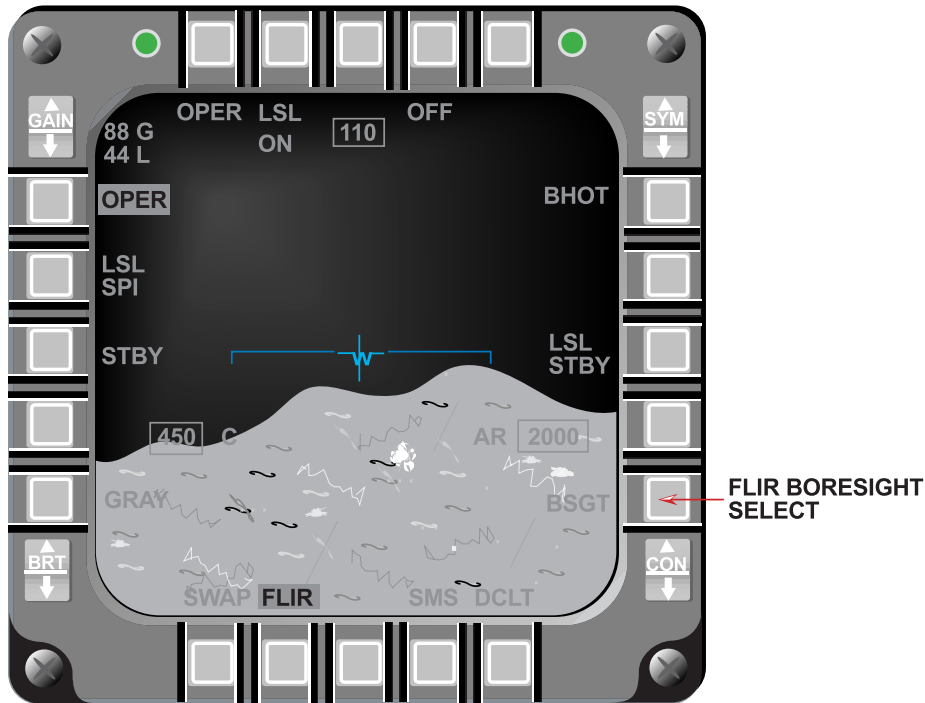

Figure 2-10 NVP FLIR Base Page (Above 1,200 Feet)

Five new NVP faults have been added to the Pilot Fault List (PFL) (Table 2-1).

Table 2-1 NVP Pilot Fault List

PFL Message	Test No.	Fault Name
NVP BUS FAIL	003	NVP BUS Fail
NVP FLIR FAIL*	006	FINS Fail
NVP TEMP*	007	Coolant Temperature Warning
NVP ECU FAIL*	008	Environmental Control Unit Fail
NVP FAIL*	010	Pod Control Computer Fail
NVP LSL FAIL*	039	LSL Fail (* Indicates new PFLs)

NVP Laser Spot Locator (RDP-1171)

The capability to locate laser designated points was added to the NVP. Laser Spot Locator (LSL) detected points can be displayed on the HUD with or without NVP video. No automatic targeting data is computed for these points. The LSL is controlled via the NVP Base page (Figure 2-11). OSB #2 (LSL OFF/WAIT/ON) commands the LSL On or Off. After depressing OSB #2 when the LSL is Off, the LSL WAIT label is displayed for approximately two minutes while the LSL powers-up. The OSB #2 label changes to LSL ON when the LSL system is powered up and OSBs #8 and #19 labels appear on the FLIR Video page. OSB #8 (LSL STBY/RDY) commands the LSL mode to standby or ready. OSB #19 selects the LSL scan pattern to Slave-to-SPI (LSL SPI) or Search (LSL SRCH).

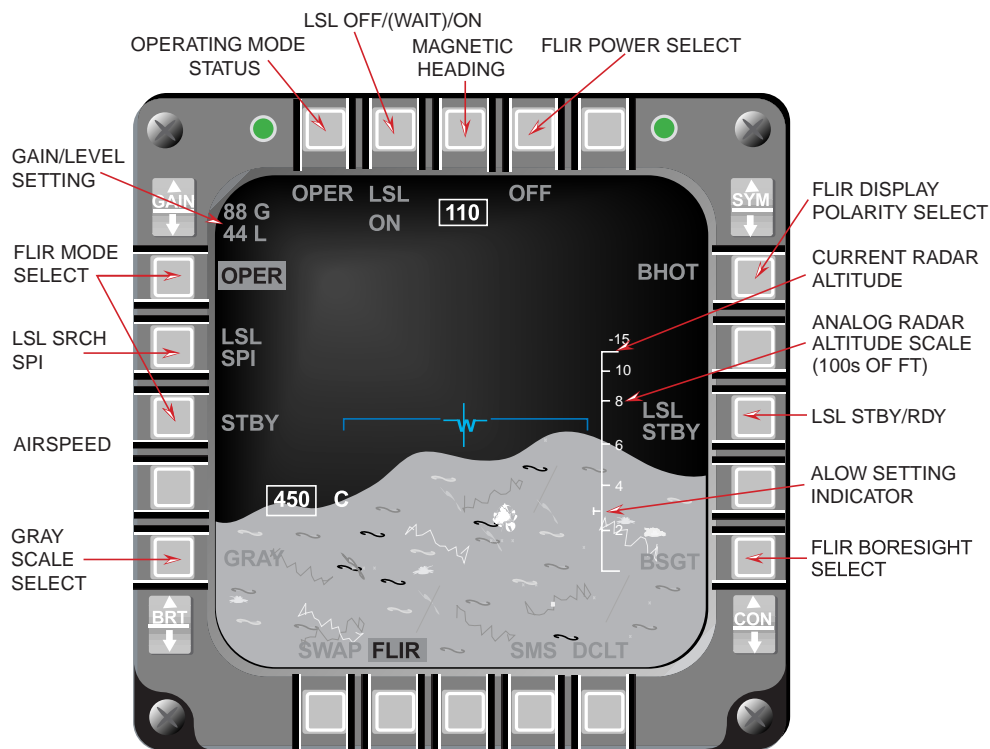

Figure 2-11 NVP FLIR Base Page (Below 1,200 Feet)

The LSL laser code is entered via the DTE load or the DED Laser page via LIST → 0 MISC → 5 LASR on the UFC.

The analog radar altitude scale only appears on the NVP FLIR Video page when descending below 1,200 feet AGL and until climbing through 1,500 feet AGL from below 1,200 feet AGL.

Include Current Master Mode In DTE Load (RDP-314)

The “last left” option was deleted for the DTE load. Upon return to the master mode in which the DTE load was made, the display formats will initialize to the format selection set by the DTE load and will not display the “last left” formats for that master mode which would include the DTE page.

Hands-On Declutter Of HUD Symbolry (Landing Phase) (RDP-869)

During the landing phase, with NAV mode selected, D&R the uncage switch will blank the roll indicator, Instrument Landing System (ILS) bars, flight director symbols, and DED data (if selected) from the HUD and the heading scale is moved to the top position. Subsequent D&Rs of the uncage switch toggle between the two HUD display formats (Figure 2-12).

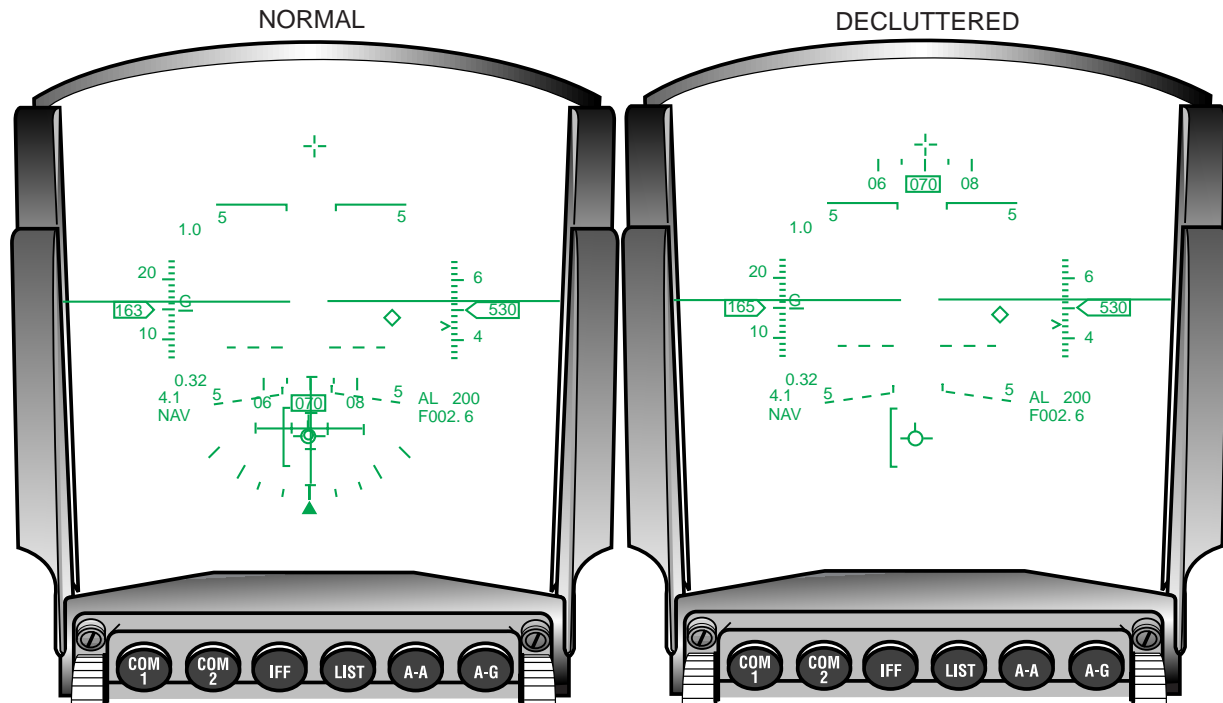

Figure 2-12 HUD Landing Mode Symbolry

When any of the following conditions occur, the HUD symbols re-appear:

- 1) NAV is exited
- 2) Landing mode is exited
- 3) Weight-on-Wheels is detected by the avionics system
- 4) A subsequent depression of the Cage/Uncage switch.

When the landing mode is exited and then re-entered, the HUD will not be decluttered.

Time-Over-Steerpoint (TOS) Refinements (RDP-259)

In M1, the Cruise Time-Over-Steerpoint (CRUS TOS) function allowed the pilot to program the avionics to provide timing and speed guidance (desired airspeed caret on the HUD) to arrive at the currently selected steerpoint at a given time. The mechanization required that a TOS be assigned to each navigation steerpoint and assumed the pilot would fly to each steerpoint in sequence.

M2 modified the mechanization to compute and display TOS guidance only to the next steerpoint having a valid TOS (not necessarily the currently selected steerpoint). The mechanization still assumes the pilot will fly sequentially through each subsequent steerpoint prior to the

next steerpoint with a valid TOS. The cruise TOS function uses steerpoints with "invalid" TOS to define the route and time to the steerpoints with valid TOS. As a result, the TOS windows of all associated UFC DED pages (STPT, DEST DIR, or CRUS TOS DED) have been increased by one character. The additional character allows entry of a minus sign to identify steerpoints having an invalid TOS.

The steerpoint TOS may be set manually through the UFC or programmed on the DTC during mission planning. An invalid TOS is manually entered on the DED- STPT, DEST DIR, or CRUS TOS pages by selecting TOS and depressing the minus sign (button 0) and "ENTR." The DTC Loader/Reader defaults all steerpoints to invalid TOS unless declared otherwise in the DTC load.

With TOS mode selected, the HUD desired Airspeed (A/S) caret is computed for the next steerpoint with a valid TOS and the HUD ETA depiction is calculated for the currently selected steerpoint. When the CRUS TOS page is displayed and the selected steerpoint has an invalid TOS, the DES TOS field is blanked. The ETA (Estimated Time of Arrival) and REQ A/S (Required Airspeed) is displayed for the next steerpoint, in sequence, having a valid TOS (Figure 2-13).

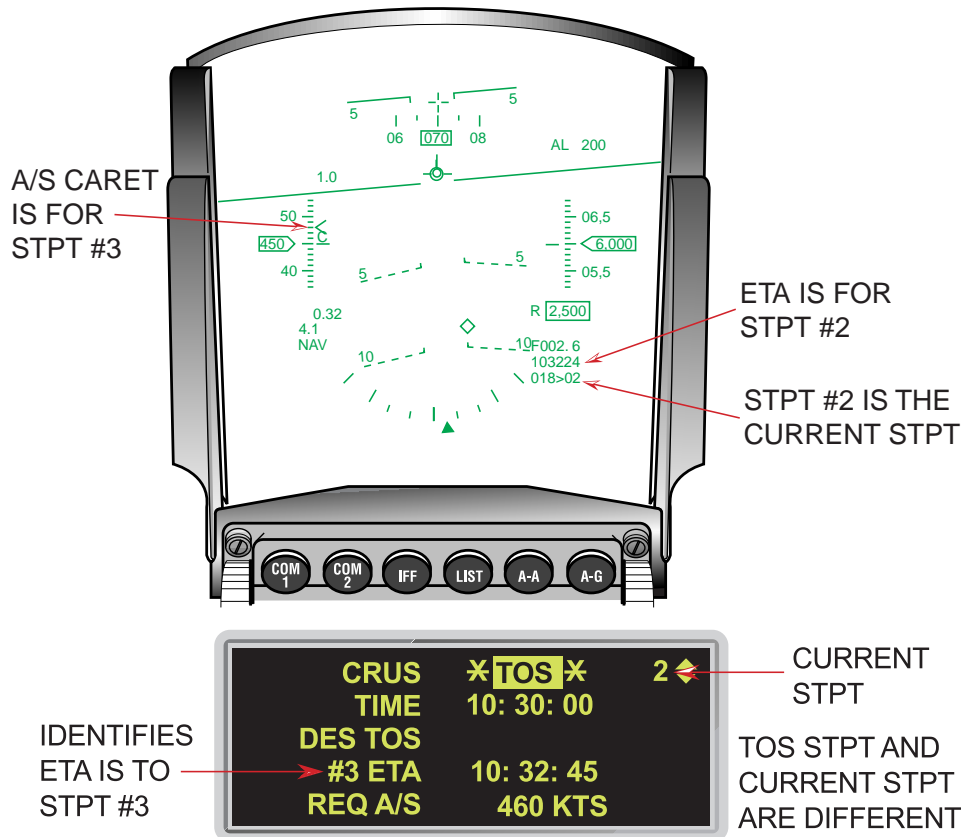

Figure 2-13 ETA On HUD And DED With Valid TOS

When the selected steerpoint and all subsequent steerpoints have invalid TOS entries, the desired A/S caret is blanked from the HUD. In addition, the DES TOS and REQ A/S fields are blanked on the CRUS TOS DED page. The HUD and CRUS TOS page ETA, are to the currently selected steerpoint (Figure 2-14).

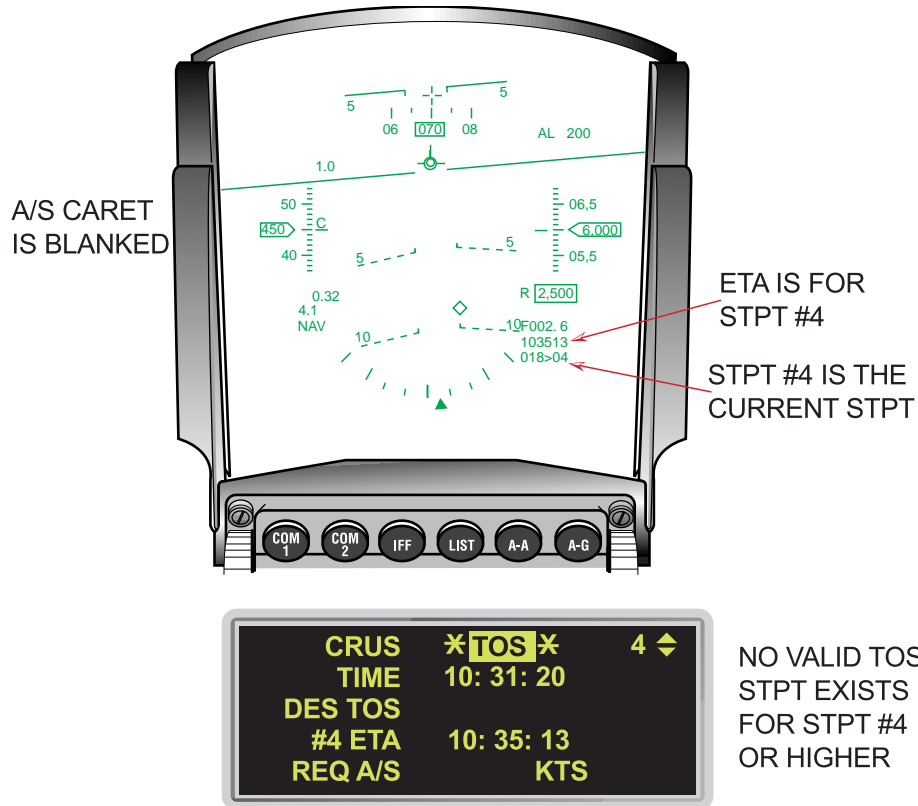

Figure 2-14 ETA On HUD And DED With No Subsequent Valid TOS

The Modular Mission Computer (MMC) defaults TOS values to last left during power cycles in-flight and on the ground when the INS is aligned. TOS is set to invalid during ground power cycles when the INS is not aligned.

UTM Coordinate Entry Up To Four Digits (RDP-597)

The Universal Transverse Mecator (UTM) DIR page (Figure 2-15) has been modified to accept UTM Easting and Northing coordinates up to four digits to provide 10 meter accuracy. The numbers in the three rows (E/N, ELEV, and TOS) are right justified to align the values.



Figure 2-15 DED UTM DIR Page

SECTION 3 - AIR-TO-AIR

This section introduces the following Air-to-Air enhancements:

- AIFF Mode Interrogation Enhancement
- Auto Time Mode Enhancement
- AIFF Interrogator Coupling To IFF Transponder Modes
- AIFF Changes And AIFF Target Display Conflict
- SCAN/LOS Mechanization
- IFF Mode Number Inside AIFF Response Symbology
- Improved IDM Mechanization
- IDM Automatic Target Hand-Off System (ATHS)
- IDM-Allow A/A Target Assignments In Continuous Mode
- Highlight CONT Mnemonic To Indicate Active CONT Operation
- IDM-Expand Net Size To 8 Members
- IDM SEAD Changes
- ASSIGN Message In HUD
- Ownship Symbol Occlusion By Team Member Data Link Symbols On HSD
- IDM Message Zeroize
- Flexible Data Link Steerpoints (71-80)
- ACM-One Switch Action To NO-RAD
- Bug Stepping To Track Files Limited To Selected Range
- SAM Multi-Track Mode Transfer Remechanization
- Breaklock Reacquisition Symbology In SAM
- Cursor Digital Search Altitude Information
- HUD Ownship Bull's-Eye
- Update Bull's-Eye Position In Expand
- LANTIRN Targeting Pod Interface
- Attitude Awareness In DGFT
- Target Altitude In HUD
- Heads Up Indication Of Imminent Radar Break Track
- EEGS Improvements: Flexible MRGS
- EEGS Improvements: Clamp MPLS
- Remove Max Range Dot When In Range
- Continuous FEDS
- No-Lock Training Mode
- Remech Hands-on Missile Select
- AIM-9L/M Bore/Slave Operations
- AIM-9 Auto Acquisition Mechanization
- Weapon Selection Not Affected By Inventory Manipulations
- AMRAAM DLZ Changes
- AMRAAM LOFT Cue
- AMRAAM Impact Remechanization
- New AMRAAM Versions
- AIM-120 Active Range Indications

- AIM-120 Launch Against Marginal Track Files
- AMRAAM Burn
- LOSE Cue In HUD Remechanization

AIFF Mode Interrogation Enhancement (RDP-878)

The Advanced Identification Friend or Foe(AIFF) interrogation capability was expanded to include Ground Map (GM), Fixed Target Track (FTT), Ground Moving Target Indicator (GMTI), Sea (SEA), Beacon (BCN), and Air to Ground Ranging (AGR) radar modes. The same interrogation procedures and rules used in A-A apply to A-G AIFF interrogation operations. However, interrogator control functions are not available on the A-G radar pages.

Interrogations are initiated by depressing the Target Management Switch (TMS) left when the FCR is in OFF, Standby, or any of the A-G radar modes above. Interrogations are inhibited when the SOI is on the Weapon (WPN), Reconnaissance (RECCE), or Targeting Pod (TGP) page. Instead, RECCE, WPN, or TGP mechanization-unique functions are performed when TMS left is activated. Interrogations are also inhibited when the HSD is the SOI and a valid IDM Data Link (DL) TOI exists. TMS left with a valid IDM DL TOI commands the UFC to display the CAS or DL SEAD page per IDM A-G baseline operation.

A-G AIFF interrogation response symbols are the same as A-A AIFF symbols, however, responses are inhibited in Expand, Freeze and FTT submodes. During interrogations in GMTI, the Map Gain label at OSB #16 is overwritten by the AIFF interrogation mode. The AIFF mode set (Scan/LOS) is not displayed below the AIFF mode on the A-G FCR formats. The selected modes and codes for interrogation do not change when switching between A-A and A-G radar modes.

Auto Time Mode Enhancement (RDP-879)

The distinct time code entries for the AIFF auto time mode has been increased from six to twelve. The time code entries are loaded via the DTE or by the pilot via the UFC. The AIFF Time (TIM) page has been modified to accept two digits to allow up to twelve time entries.

AIFF Interrogator Coupling To IFF Transponder Modes (RDP-1235);AIFF Changes And AIFF Target Display Conflict (RDP-1702)

M2 provides the option to couple/de-couple modes and codes to the Manual Transponder page or any Auto Transponder page. The Interrogator page is coupled when “CPL” is selected and highlighted on the appropriate DED page. There are independent pages for the SCAN and LOS interrogator modes (Figure 3-1). When the Interrogator page is de-coupled, the modes and codes are retained through mode/code changes on the active Transponder page. When an Interrogator page is coupled to the active Transponder page, the active modes/codes overwrite the existing modes/codes on the Interrogator page. Any changes that are made to the active page when the Interrogator page is coupled are reflected on the selected Interrogator page(s). The design includes:

- 1) The scratchpad on the coupled Interrogator pages ignores any entries except for “IJAM (7)” and “CPL/DCPL (9)”
- 2) The scratchpad on the de-coupled Interrogator page works per baseline

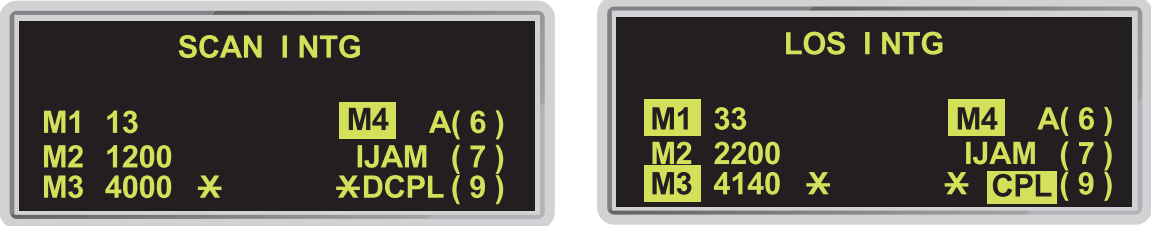

Figure 3-1 SCAN And LOS INTG Pages Decoupled

The AUTO IFF modes and codes used by the system are based on which function is “active” at the current time. Four different functions can be active: MAN, TIM, POS, and POS/TIM. The TIM function changes the IFF codes based on a time reference. The POS functions changes the modes based on a position reference. When TIM is active, the system uses the codes from the TIM page and the modes from the MAN page. When POS is active, the system uses modes from the POS page and the codes from the MAN page. When both the POS and TIM (P/T) functions are active, modes change based on position and codes change based on time. When neither POS or TIM is active, the MAN function is active and the system uses the modes and codes from the MAN page (Figure 3-2).

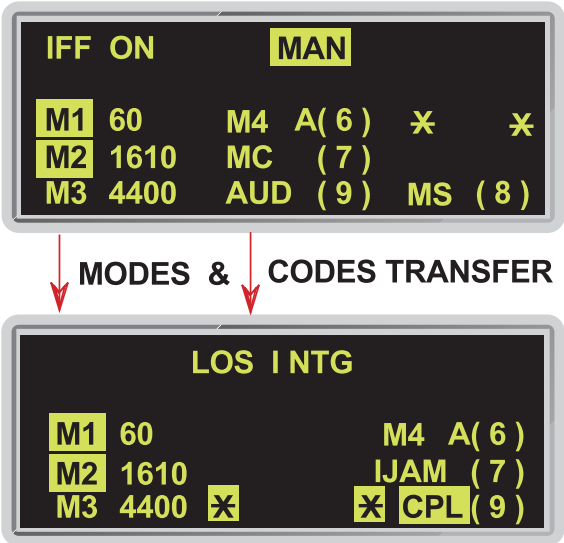

Figure 3-2 LOS INTG Page Coupled To The Active Manual Page

When TIM is active, the codes on the coupled Interrogator page (Figure 3-3) are overwritten by the TIM codes. The interrogator modes are not changed; however, the pilot has the ability to change the modes as desired.

When POS is active, the modes on the coupled Interrogator page (Figure 3-4) are overwritten by the POS modes. The interrogator codes are not changed; however, the pilot has the ability to change the codes as desired.

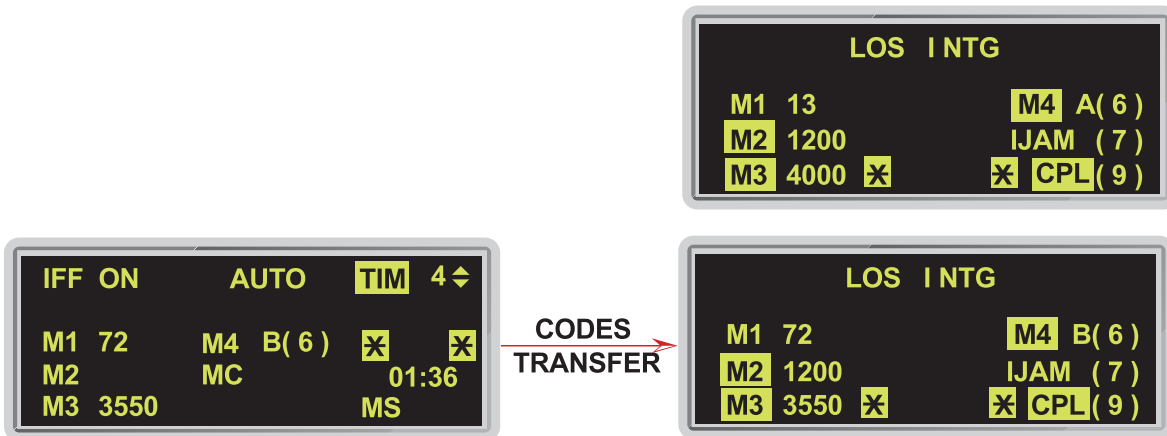

Figure 3-3 SCAN INTG Page Coupled To The Active AUTO TIM Page

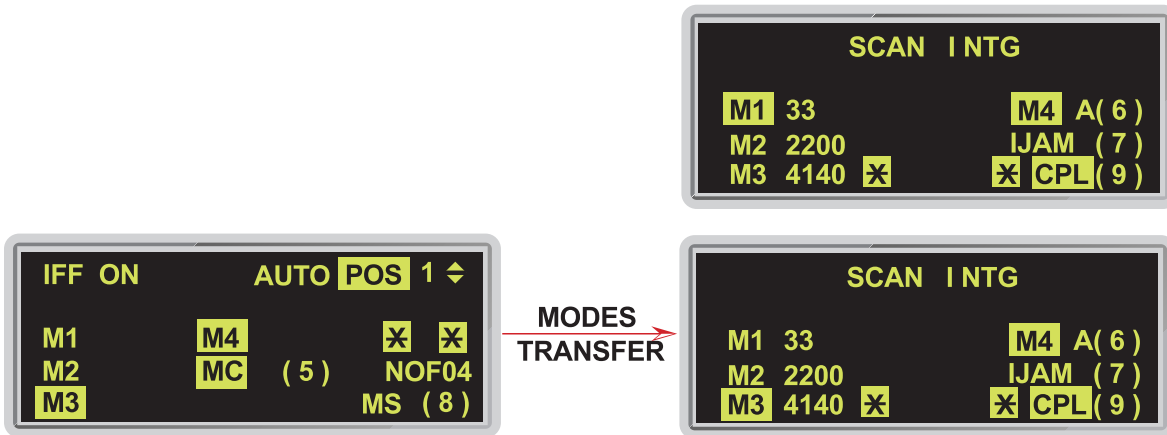

Figure 3-4 LOS INTG Page Coupled To The Active AUTO POS Page

When both POS and TIM (P/T) are active, the modes on the coupled Interrogator page are overwritten by the POS modes and the codes are overwritten by the TIM codes (Figure 3-5). The pilot maintains the ability to change the modes and codes by making the Manual Transponder page active and entering the desired modes and codes.

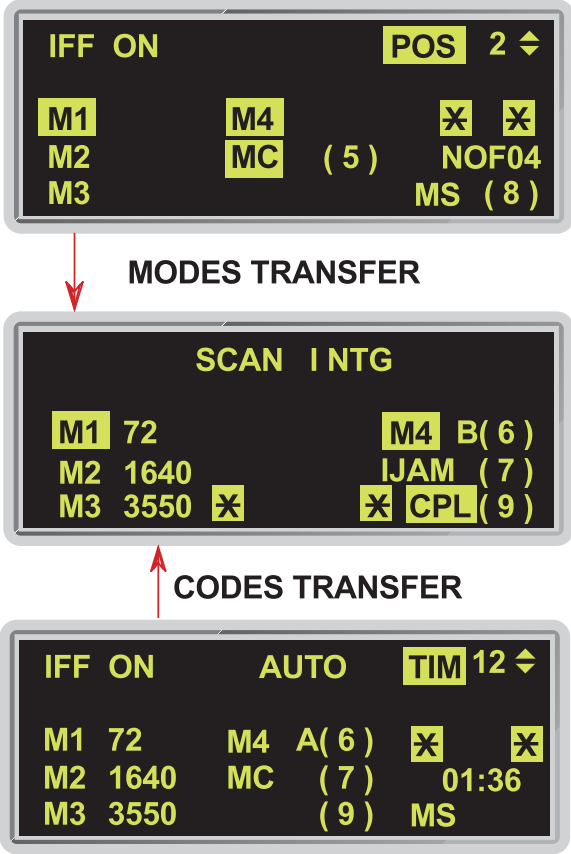

Figure 3-5 SCAN INTG Page Coupled To The Active IFF POS/TIM Pages

SCAN/LOS Mechanization (RDP-1236)

M2 provides the ability to select single or multiple mode interrogations for SCAN or LOS interrogations. TMS left for <0.5 seconds commands SCAN interrogation and TMS left for >0.5 seconds commands a LOS interrogation. A single mode interrogation is selected via OSB #16 on the FCR page (Figure 3-6) independent of the modes selected on the DED Interrogator page and is indicated by M# (where # is the selected mode). Multiple mode interrogations, as selected on the DED Interrogator page (Figure 3-7), is indicated by M+ on the FCR page and clues the MMC to refer to the DED Interrogator page to determine the modes to be interrogated.

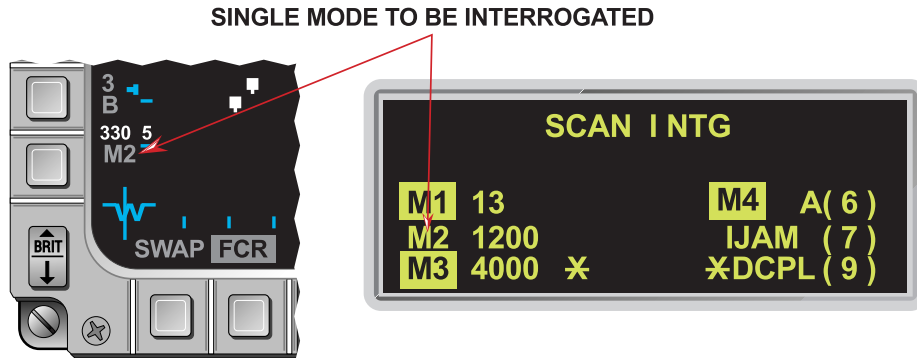

Figure 3-6 Single Mode Interrogation Selected

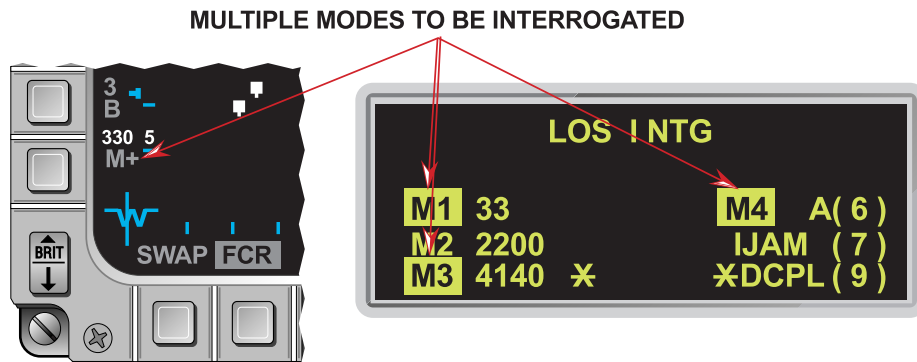

Figure 3-7 Multiple Mode Interrogation Selected

IFF Mode Number Inside AIFF Response Symbology (RDP-1237)

Target replies from SCAN or LOS interrogations are displayed on the FCR format (Figure 3-8) with the mode number inside the symbol with the same priority and color as the displayed reply.

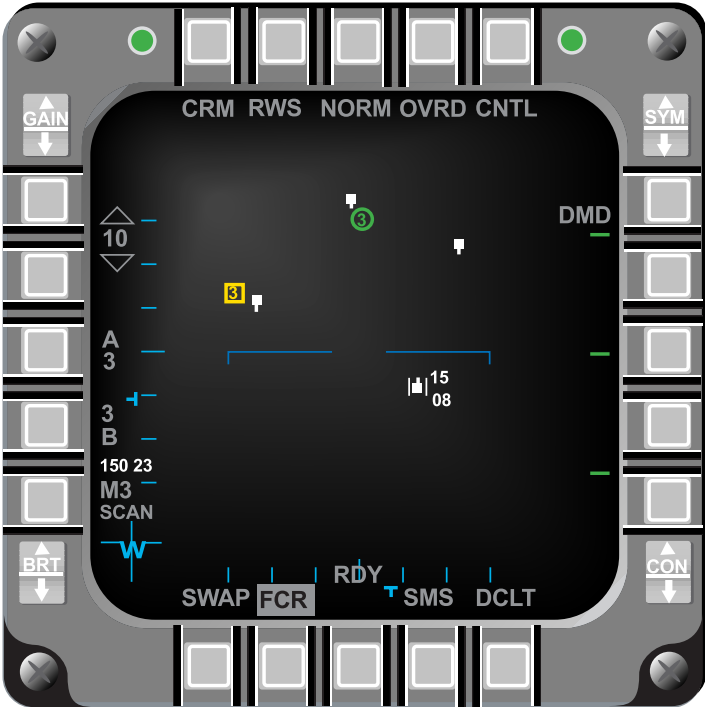

Figure 3-8 AIFF Interrogation Replies On The FCR Page

Improved IDM Mechanization (RDP-1366)

Data link symbology is displayed on the FCR page in the DEMAND mode. The data link symbology can be removed from the FCR page by pressing the COM switch outboard for <0.5 seconds. Pressing the COM switch outboard for >0.5 seconds (within the 8-sec. timeout) displays the previously displayed data link information on the FCR page provided the information remains valid.

Assignments can be made in the DEMAND mode. Upon receipt of a new assignment or round, the new information is displayed on the FCR page.

IDM Automatic Target Hand-Off System (ATHS) (RDP-868)

M2 adds the capability to transmit a Close Air Support (CAS) On Station message and receive a CAS Mission Update (9-line briefing) message via the IDM in both the Air Force Application Program Development (AFAPD) and Army Tactical Fire Support (TACFIRE) protocols. The UFC has been expanded to include an On Station, A-G DL initialization, Mission Update, CAS IP, and CAS TGT DED pages.

Depressing LIST and ENTR on the UFC displays the On Station (ON STA) page. Depressing the DCS to Sequence (SEQ) from the ON STA page steps to the A-G DL page (Figure 3-9). The A-G DL page allows entry/selection of the following parameters for transmission and reception of CAS On Station and Mission Update messages. With the exception of item 4 below, the selections on the A-G DL page have no impact on the Intra-flight data link transmissions.

- 1) **Transmit Address (XMT):** The Transmit Address field depends on the currently selected protocol shown in the PRTL field. With TACF protocol selected, the Transmit Address is a 1-character alpha-numeric entry that can only be changed with the Increment/Decrement (INC/DEC) switch. When the asterisks are about the Transmit Address field, INC/DEC symbols are displayed adjacent to the field. Increment steps the alpha-numeric rotary in "increasing" order; 0 through 9 and then A through Z. Decrement steps the rotary in reverse order. Holding INC/DEC down for more than 0.5 sec. auto-steps the rotary at a rate of 3 characters per second. When the asterisks are moved from the Transmit Address field, the Inc/Dec symbols are removed. The Transmit Address for AFAPD protocol is a 2-digit numeral that is entered using UFC buttons 1-9 followed by ENTR. When the protocol type is changed, the Transmit Address defaults to the last selected Transmit Address associated with the new protocol.
- 2) **Own ship Address (OWN):** Ownship Address entries are also protocol dependent and are similar to Transmit Addresses. With TACFIRE protocol selected, placing the asterisks about this field causes the INC/DEC symbols to be displayed adjacent to the field. INC/DEC rotaries the own ship address from 0 through 9 and then A through Z. With AFAPD selected, the ownship address is a two-digit address entered from the UFC (Buttons 1-9). When the protocol is changed, the Ownship Address defaults to the last Ownship Address for the selected protocol.
- 3) **Fill Option (FILL):** ALL/NONE. Selection is via any key 1-9.
- 4) **Communications (COMM) Selection:** With the asterisks about the COMM field, depressing any key 1-9 selects the radio that will be used to transmit the On Station and Mission Update messages. Selection of UHF automatically de-faults Intra-flight data link transmissions to the VHF radio and vice-versa.
- 5) **Data Rate (DATA):** Depressing any key 1-9 with the asterisks about the DATA field rotaries through the transmission rates of the On Station and Mission Update messages between 16K (16,000), 8K (8,000), 2.4K (2400), and 1200 bits per second (bps).
- 6) **Protocol (PRTL):** Depressing any key 1-9 with the asterisks about the PRTL field toggles between the TACF and the AFAPD protocols.
- 7) **Steerpoint Number:** When the asterisks are positioned about the steerpoint number, the UFC positions the INC/DEC symbol adjacent to the steerpoint. The INC/DEC buttons function in a normal manner.

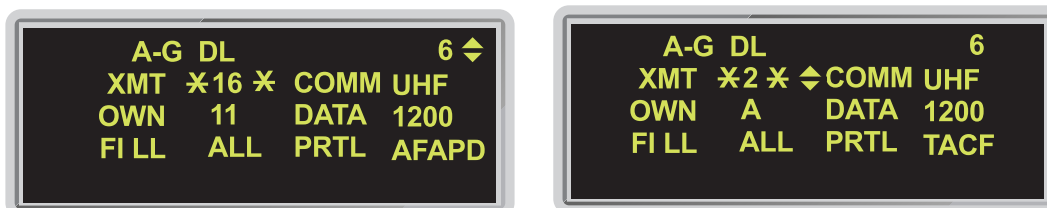

Figure 3-9 A-G DL Initialization Pages For AFAPD And TACF Protocols

NOTE:

In order to receive and transmit messages to one another, the participants must have the same data rate and protocol selected.

Mission Update Message (Receive Only):

When a CAS message is received, the mnemonic "CAS## DATA" is displayed in the center of the HUD and a VMU message "Data" is broadcast. The HUD mnemonic remains displayed until either Warn Reset is depressed and released or the CAS page is selected. "##" indicates the steerpoint number where the CAS message is stored.

CAS messages are stored in steerpoints 71-80, which are shared locations with Penguin and Mark-point data link messages. Received messages (CAS, Penguin, and/or Mark-point) are sequentially stored in steerpoints 71-80. When the steerpoint range is full, the system wraps back to steerpoint 71 and overwrites the old data stored there. Stored CAS messages are retained through MMC power cycles when airborne and are cleared at the start of a new mission (mission reset).

CAS messages received in AFAPD protocol are stored in an Initial Point (IP) and a Target (TGT) location for steerpoints 71-80. The received CAS IP and TGT are displayed on the HSD provided they are within the HSD FOV. The IP is displayed as a square and the TGT as a triangle (Figure 3-10). Hands-on selection of CAS messages (displaying the CAS page on the DED) and selecting the CAS IP or CAS TGT as the current steerpoint, is available only when the SOI is on the HSD. For example:

- 1) TMS Forward (Designate): Designating on a CAS IP or TGT symbol on the HSD, places a square around ("boxes") the symbol and establishes the point as the current Data Link Target Of Interest (DL TOI). Designating on a boxed CAS IP or TGT converts the DL TOI to the currently selected steerpoint and fills-in the symbol (square or triangle) on the HSD.
- 2) TMS Right (RT): Selects the last received CAS message and places a square around ("boxes") the CAS IP or CAS TGT if no IP is available. A subsequent TMS RT steps the box to the CAS TGT (if a CAS IP was boxed) or next CAS STPT in sequence (STPTs 71-80) if a CAS TGT was boxed. A TMS RT from steerpoint 80 will cause the system to wrap back to steerpoint 71 in search of the next available CAS steerpoint.
- 3) TMS Left (LT): Displays the CAS DED page; or, if the CAS DED page is being displayed, sequences to the next CAS DED page in the rotary (STPTs 71-80).
- 4) TMS Aft: Drops a boxed CAS IP or CAS TGT.

NOTE:

When an AFAPD CAS message is received, full IP and TGT data are available via the three CAS pages shown in Figure 3-12. TACFIRE CAS messages only provide target data on a single CAS page (Figure 3-13). Latitude, longitude, elevation and TOS can be updated on the CAS Destination pages (Figure 3-14) and CAS Steerpoint pages.

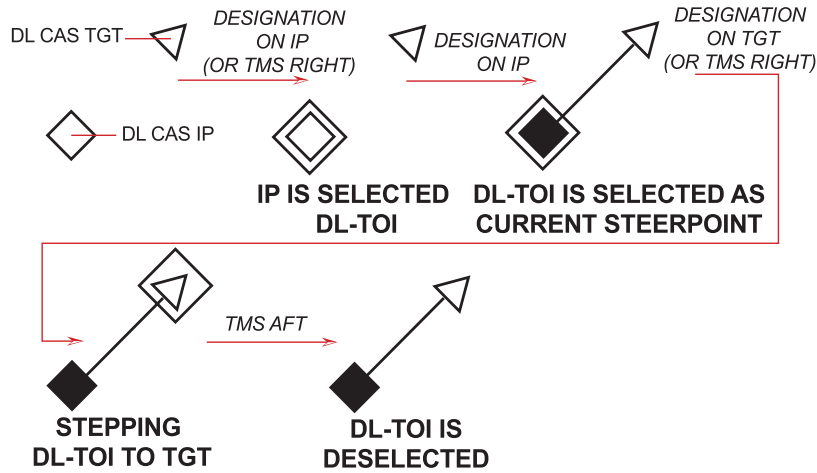

Figure 3-10 Hands-On DL CAS IP/TGT Selection

On Station Message (Transmit Only):

The CAS On Station message must initially be loaded from the DTC to be available for transmission. The CAS On STA page (Figure 3-11) is accessed via LIST and ENTR on the UFC. The asterisk rotary for the On Station page is XMT, Call Sign Number, Number of Aircraft, Station Time, and Abort Code. With the asterisks about "XMT," depressing and releasing M-SEL transmits the On Station message and highlights "XMT" during the IDM transmission to the addressee shown to the right of the "XMT" mnemonic on the A-G DL page (Figure 3-9).

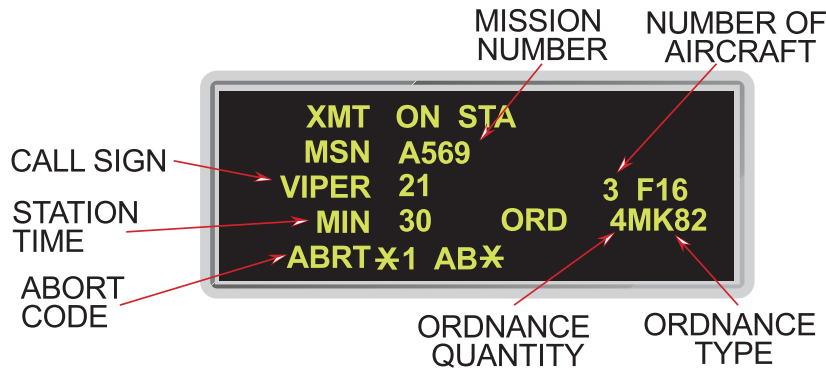

Figure 3-11 CAS On Station Page

Once loaded the following ON STA page parameters can be changed:

- 1) Call Sign Number: Defaults to the DTC load (00-99 excluding multiples of 10. i.e., 10, 20, 30 etc).
- 2) Station Time (MIN): Defaults to DTC load (0-99)
- 3) Number of Aircraft: Defaults to DTC load (0-9)
- 4) Abort Code: Rotary sequences Abort Code number/code pair (1-5)

When an AFAPD CAS message is received, full IP and TGT data are available via three DED CAS pages (Figure 3-12). TACFIRE CAS messages only provide target data on a single DED CAS page (Figure 3-13). Latitude, longitude, elevation and TOS can be updated on the CAS Destination page (Figure 3-14) and CAS Steerpoint page.

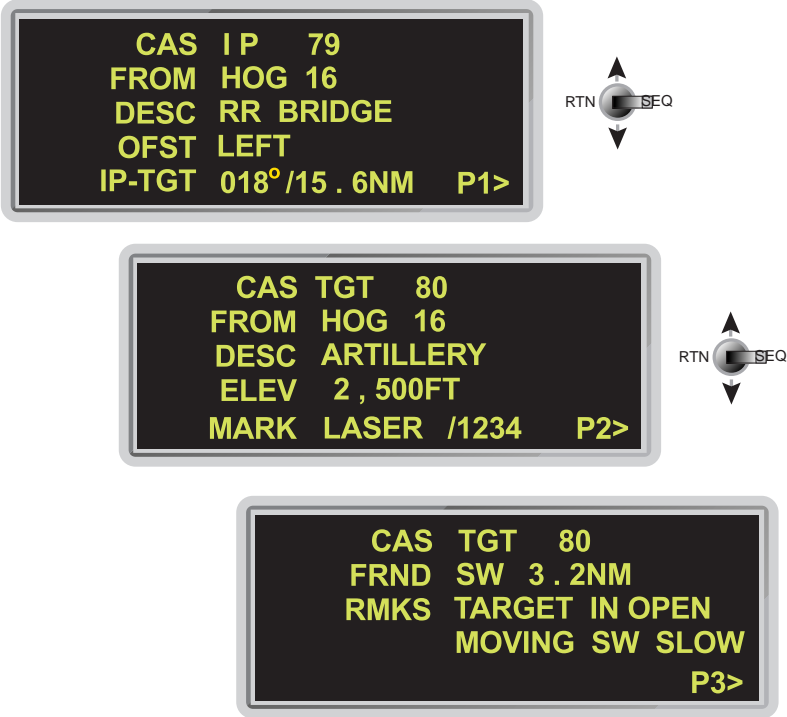

Figure 3-12 AFAPD CAS Mission Update Pages



Figure 3-13 TACFIRE CAS Mission Update Page

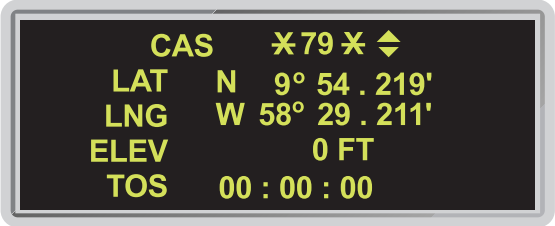

Figure 3-14 CAS Steerpoint Destination Page

IDM-Allow A/A Target Assignments In Continuous Mode (RDP-875)

The Improved Data Modem (IDM) has been modified such that the Assign (ASGN) and Continuous (CONT) modes allow data link assignments of the current FCR Target Of Interest (TOI) to another team member via OSB #7 through #10 on the FCR format. The selected OSB label highlights and changes to "XMT". The assignment message is broadcast to the intraflight team and consists of position, velocity, and heading of the assigned target. DL unknown and team member target symbols are displayed for 8 seconds on the FCR and HSD formats. No change was made to the baseline method of assigning FCR targets via the IDM. An intraflight round can be requested in the ASGN mode for display on the A-A FCR and/or HSD formats.

Highlight CONT Mnemonic To Indicate Active CONT Operation (RDP-1239)

The CONT mnemonic is highlighted on the MFD (Figure 3-15) when a CONT round is commanded and remains highlighted to indicate your aircraft is the CONT round controller. When a A-A request is received from another aircraft (transition out as CONT controller), or when a transition to RF Quiet/Silent (detected by the MMC), the CONT highlight is removed.

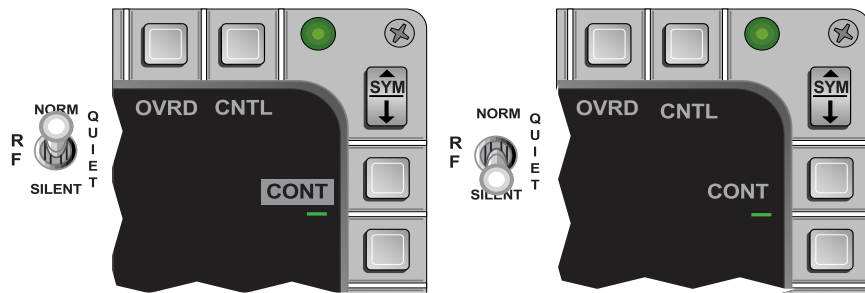

Figure 3-15 Continuous Mode Active/Silent

IDM-Expand Net Size To 8 Members (RDP-872)

The DED Intraflight page (Figure 3-16) has been modified to allow entry/setup for 8 team member addresses. The HSD format provides the display of up to 8 DL friendly positions and Identifications (ID). IDs 1 to 4 represent your 4-ship team package with the ID (1-4) above the aircraft symbol. A-A data link assignments can only be made among this four ship package. The second four ship package (Team IDs 5-8) is displayed with their team address (two digit number) above the symbol.

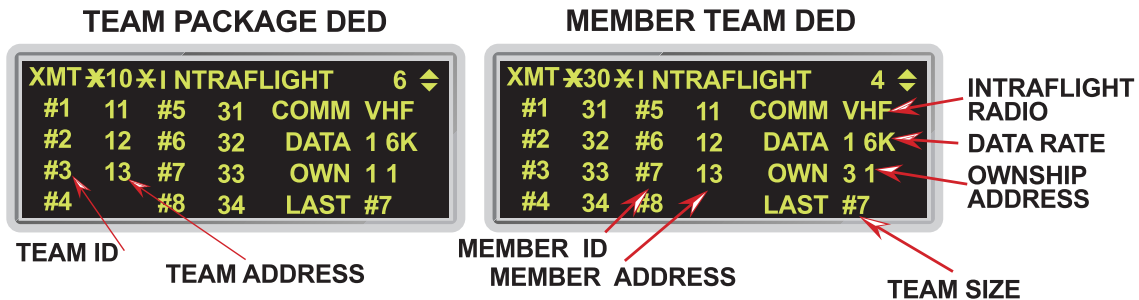

Figure 3-16 DED Intraflight Initialization Page

The MFDs display up to 8 DL unknown symbols: the bugged target of the four team members and the team members assignments. The MFDs display 1 through 4 centered above the symbols for team members (1-4). The Team Address (##) is displayed above the four DL Friendly Team members (5-8) (Figure 3-17). Bugged targets for team members 5 to 8 are not displayed. Data link targets outside of the FOV arrows (see SECTION 1 - RDP-884) are only displayed for the 4-ship team (3-ship in Figure 3-16).

Round time for eight members was expanded to approximately 12-14 seconds followed by a variable delay (DTC loadable 1.4 to 5.5 sec. in continuous mode). If the team size is less than eight, the round time is adjusted according to the number of team members. The display timer was reduced to 8 seconds for DL Team Member, DL Friendly, and DL Team member's Unknown TOI symbols. These symbols no longer flash the last five seconds in any mode (assign, continuous, or demand).

When a Friendly Team Member (5-8) passes his A-G cursor position, his symbol is displayed with his Team Address (##) above the symbol (Figure 3-17).

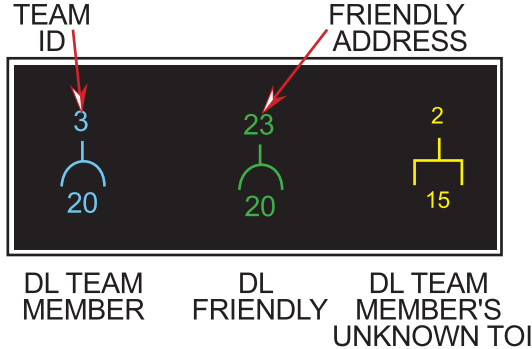

Figure 3-17 MFD Data Link Friendly And Unknown Symbols

IDM SEAD Changes (RDP-1015)

M2 modified the HSD controls and displays to improve the ability to recognize and manipulate data link targets received by the system. The enhancements include:

- 1) More unique SEAD threat symbols
- 2) Mipple the threat symbol and "DL" until the data link threat is boxed or warn reset is depressed
- 3) Hands-on designating the most recently received threat on the HSD when the DL TOI already exists

When a SEAD DL threat is received, the threat symbol and "DL" mipple to alert the pilot to its position on the HSD until boxed or Warn Reset is depressed. Designating over a threat boxes the threat and stops the mipple. Depressing Warn Reset stops the mipple of all threats. After the threat has been boxed or WARN RESET is depressed, the threat symbol remains steady with a slash "/" across the symbol. (See Figure 4-28.)

With the SOI on the HSD and a SEAD symbol boxed, a TMS-right command for less than one second steps the box among the displayed data link SEAD symbols. Likewise, if a CAS symbol is boxed, a TMS-right for less than one second steps the box among CAS symbols. TMS-

right-and-hold for greater than one second auto-designates the latest DL message. If no data link targets have been received, the TMS-right-and-hold command is ignored. If the auto-designate data link target is a DL SEAD threat and its position is outside the current HSD FOV, the range scale will increase up to a maximum of 120 nautical miles depressed or 80 nautical miles centered, as required to display the threat. At maximum range, if the threat is still beyond the HSD FOV, the threat will be displayed using an outside-FOV symbol (filled-in triangle) along the outer range ring at the correct azimuth pointing toward the target.

If the DED DL SEAD or CAS page is displayed for a DL target and a new DL target is boxed, the DED page will update with the new DL target data. For additional information concerning DL SEAD operations, see SECTION 4-HARM DL Mode.

ASSIGN Message In HUD (RDP-1242)

“ASSIGN” is displayed in the HUD for 8 seconds (the same as the display time on the assignment unknown track on the MFD) upon receipt on an ASSIGN message. Depressing WARN RESET removes the “ASSIGN” cue from the HUD.

Ownship Symbol Occlusion By Team Member Data Link Symbols On HSD (RDP-1241)

The ownship symbol and the team member data link symbols have the same occlusion priority level on the HSD. This allows the relative positions of team members to be determined when the team members and the ownship symbols overlap.

IDM Messages Zeroize (RDP-983)

M2 provides the capability to delete DL SEAD and CAS (IP and TGT) messages via hands-on controls. Designating the DL SEAD target text on the HSD places a box about the DL target text. With the cursor over the box and TMS aft for greater than one second deletes the DL SEAD message from the system and removes the target text from the HSD. The same procedure deletes a CAS message from the system by designating either the IP or target symbol. Placing the cursor over the box and TMS aft for greater than one second deletes the DL CAS message from the system for both the IP and target and removes the IP and target symbols from the HSD. TACFIRE CAS messages only contain target information. TMS aft for less than one second removes the box from the target. When a data link target is deleted, the lat/long/elev of the steerpoint is zeroed, and the TOS is set to -0. In addition, stored SEAD or CAS information is deleted.

Flexible Data Link Steerpoints (71-80) (RDP-873)

M2 modified the steerpoint data link mechanization to make data link steerpoint entry more flexible. Data link steerpoints are stored in steerpoint positions 71 to 80. The avionics system does not use weapon load information to determine whether or not to accept a data link steerpoint.

Steerpoint 30 has been grouped with steerpoints 26-29 for storing ownship Mark points. The HSD displays the location of each DL markpoint (STPT 71-80) as a large “**X**”, while ownship markpoints (STPT 26-30) are displayed as a small “**x**”. data link markpoints are cleared when a Mission Reset occurs.

ACM-One Switch Action To NO-RAD (RDP-626)

The Target Management Switch (TMS) aft (RTS) function was changed as follows:

- 1) Any ACM radiating submode, TMS aft enters ACM 30x20 NO-RAD.
- 2) From 30x20 NO-RAD, TMS aft enters ACM 10x60 radiating submode

TMS aft is the only switch action that commands a break lock from an ACM track mode.

When ACM is entered and a submode is requested, the FCR will radiate regardless of the position of the RF switch. Moving the RF switch from NORM to QUIET or SILENT while in ACM has no effect on the radiate state. While the RF switch is in Quiet or Silent, the FCR will continue to radiate until you exit ACM without a bugged target.

Bug Stepping To Track Files Limited To Selected Range (RDP-1158)

FCR bugged target stepping is limited to track files displayed on the current FCR range scale and range is no longer bumped up to track files existing beyond the selected range.

SAM Multi-Track (SMT) Mode Transfer Remechanization (RDP-1165)

The “Last Left” mode is maintained for the following FCR CRM mode transitions:

- **SMT → RWS (TTS/SAM/STT) → SMT**
- **TWS → RWS (TTS/SAM/STT) → TWS**

Breaklock Reacquisition Symbolism In SAM (RDP-1243)

When the FCR is in SAM, a reacquisition symbol (Figure 3-18) is displayed at the last elevation of the lost bugged target on the FCR format.

NOTE:

This feature should be considered inop since it is not currently supported by the APG-66V radar.

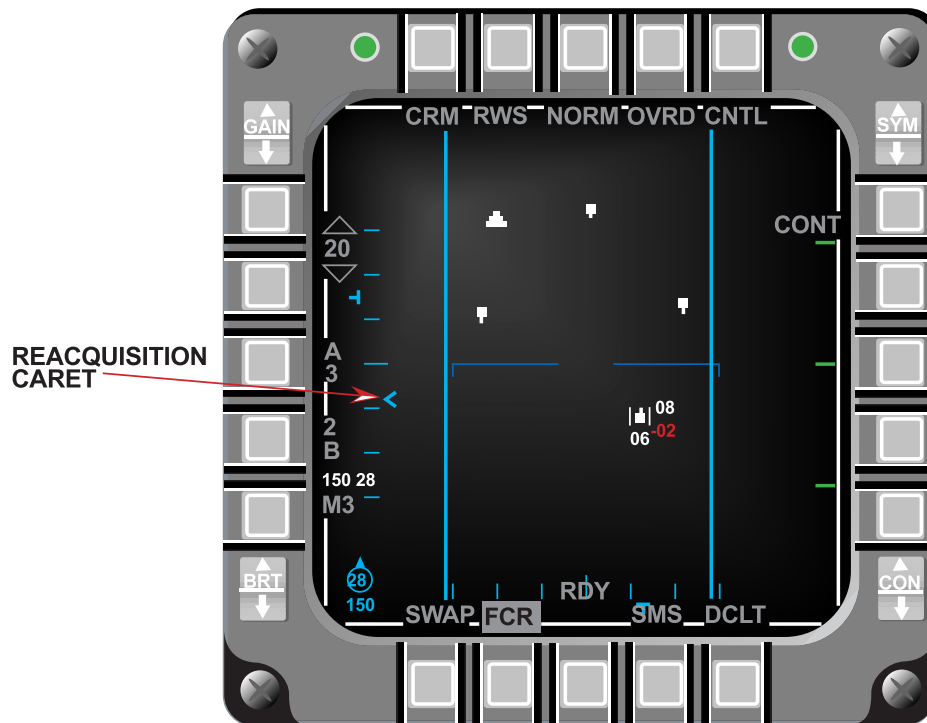

Figure 3-18 FCR CRM/RWS SAM Mode

Cursor Digital Search Altitude Information (RDP-351)

The default color for the FCR cursor minimum search altitude display for real negative values is red (Figure 3-18), however, the color is DTC loadable.

HUD Ownship Bull's-Eye (RDP-1229)

When bull's-eye bearing and range is mode selected and in an A-A FCR mode, the bearing and range from bull's-eye to ownship is displayed below the mode display (Figure 3-19) in the HUD (lower left corner). The bearing and range information is an 8 character field (3 for bearing, 2 blank spaces, followed by 3 for range) for easy interpretation.

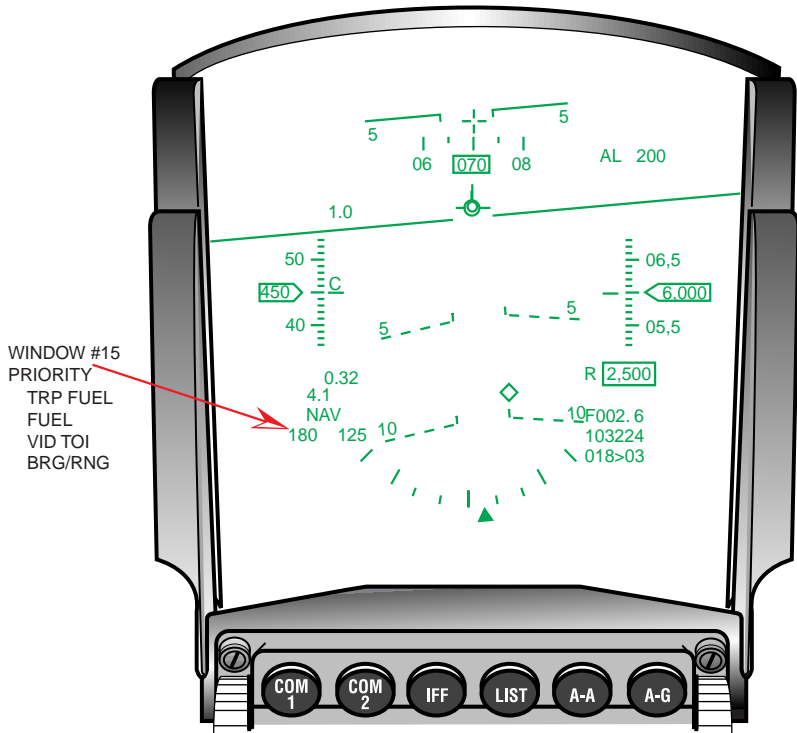

Figure 3-19 HUD Bull's-Eye Bearing And Range

HUD window #15 is a shared field, therefore, when conditions are met for GND PROX, TRP FUEL, or FUEL, the HUD displays the appropriate mnemonic. Also if the Visual Identification (VID) mode is selected, the target altitude has priority over the bull's-eye bearing and range. The message priority for this field is:

- 1) GND PROX
- 2) TRP FUEL
- 3) FUEL
- 4) VID TOI (target altitude)
- 5) Ownship Bearing and Range from Bull's-eye

Update Bull's-Eye Position In Expand (RDP-1415)

The Bull's-eye symbol is displayed in it's expanded position on the FCR EXPAND format when it is in the FCR expanded FOV.

LANTIRN Targeting Pod Interface (RDP-864)

A more complete description of the LANTIRN Targeting Pod (TGP) features, including control and display options is contained in SECTION 4 - Air-To-Ground. If a targeting pod other than LANTIRN is used, subtle operational differences may exist.

The LANTIRN TGP A-A features include:

- 1) Tracking A-A Targets
- 2) A-A TGP LOS Indicator In The HUD

- 3) Laser Ranging On A-A Targets
- 4) Slaving The FCR LOS To The TGP LOS
- 5) Slaving The AIM-9 Missile To The TGP LOS
- 6) Perform Sensor/AIM-9 LOS Correlation

TGP Tracking A-A Target:

In A-A, if an A-A bugged target is present, the TGP LOS is slaved to the FCR LOS, and if a bugged target is not present, the TGP LOS is commanded to boresight (0-degrees azimuth and minus 3-degrees elevation). The TGP may be commanded to track the FCR A-A target by moving the SOI to the TGP and activating a TMS-forward command. Without an FCR track, the pilot may maneuver the aircraft to place the target within the center of the TGP's field of view and TMS forward to command tracking. Once the TGP is tracking, it is independent of the FCR.

A-A TGP LOS Indicator On The HUD:

When the TGP is tracking an A-A target in the HUD FOV, a dotted Target Designator (TD) box is placed at the TGP LOS on the HUD. If the TGP is tracking a target outside the HUD FOV a dotted Target Locator Line (TLL) extends from the bore cross in the direction of the TGP LOS. The target angle in degrees is positioned along the TGP TLL at 65-mr from the bore cross. The A-A FCR TLL target angle is positioned 45-mr from the bore cross allowing both target angles to be read when the TLLs are close together. The TGP TD box and TLL are displayed independent of the FCR TD box and TLL.

Laser Ranging On A-A Targets:

When the A-A TGP is in Point Track with the Master Arm switch in ARM and the laser in ARM, depressing the trigger to the first detent fires the TGP laser. The reported laser range is displayed on the TGP page, if no range is reported "XXX" is displayed. Both the FCR and the TGP ranges are displayed at the same time on the HUD.

Slaving The FCR LOS To The TGP LOS:

When the TGP is tracking an A-A target with the FCR in Air Combat Mode (ACM) and TMS right is activated, the FCR commands ACM Boresight along the TGP LOS independent of SOI.

Slaving The AIM-9 Missile To The TGP LOS:

When the TGP is tracking an A-A target and is the SOI, if the selected weapon is an AIM-9 in Slave, that AIM-9 will be slaved to the TGP LOS. If the TGP is the SOI but is not tracking a target, the caged AIM-9 is slaved to the Armament Datum Line (ADL).

When the TGP is the SOI, the Dynamic Launch Zone (DLZ) is blanked, the missile diamond does not flash to indicate a good shot, and the AIM-9 missile reticle is void of the target aspect symbol and the range tics/gap.

Perform Sensor/AIM-9 LOS Correlation:

When the sensor (TGP or FCR) LOS and the AIM-9 are correlated on the same target (within 1.5 degrees of each other) outside the HUD FOV, a "C" is displayed to the left of the target angle for the respective sensor.

Attitude Awareness In DGFT (RDP-820)

Attitude awareness in DGFT is provided on the HUD through the Attitude Awareness Arc (AAA) and the Ghost Horizon Line (GHL). The Attitude Awareness Arc provides a global picture of pitch and roll attitude in the form of an arc. Roll is provided by the angle of an imaginary line through the ends of the arc in relation to the HUD. During wings level flight the arc gap is toward the top of the HUD, while during inverted flight, the arc gap is toward the bottom of the HUD (Figure 3-20) and indicates the upright attitude. The arc represents the ground.

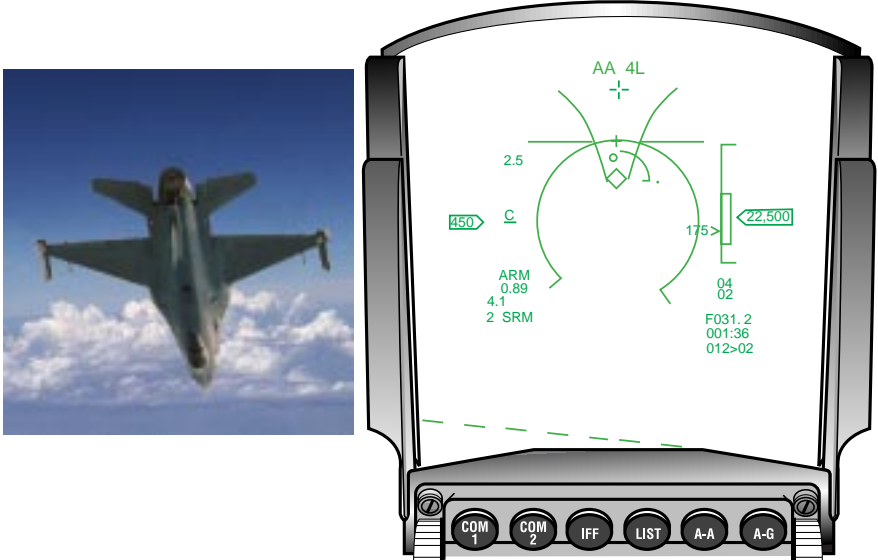

Figure 3-20 Nose-down Inverted Attitude Awareness Arc

The attitude arc is not adjusted for winds or aircraft yaw and is roll stabilized about the center of the HUD Total Field Of View (TFOV). The curvature of the arc represents the direction of the ground, and an imaginary line connecting the ends of the arc represents a line parallel to the horizon. In level flight the arc forms a half circle. As the aircraft increases nose-up pitch, the arc length decreases (Figure 3-21). As the aircraft noses over below the horizon, the arc length increases (Figure 3-22). The arc is at its smallest length at 87-degrees nose-up and is at its longest length at 87-degrees nose-down.

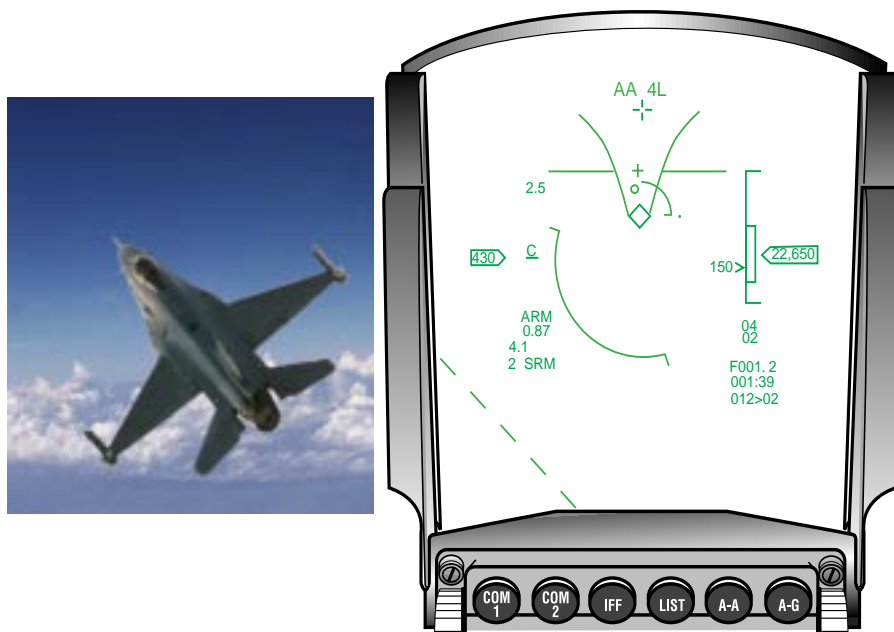

Figure 3-21 Left Climbing Bank Attitude Awareness Arc

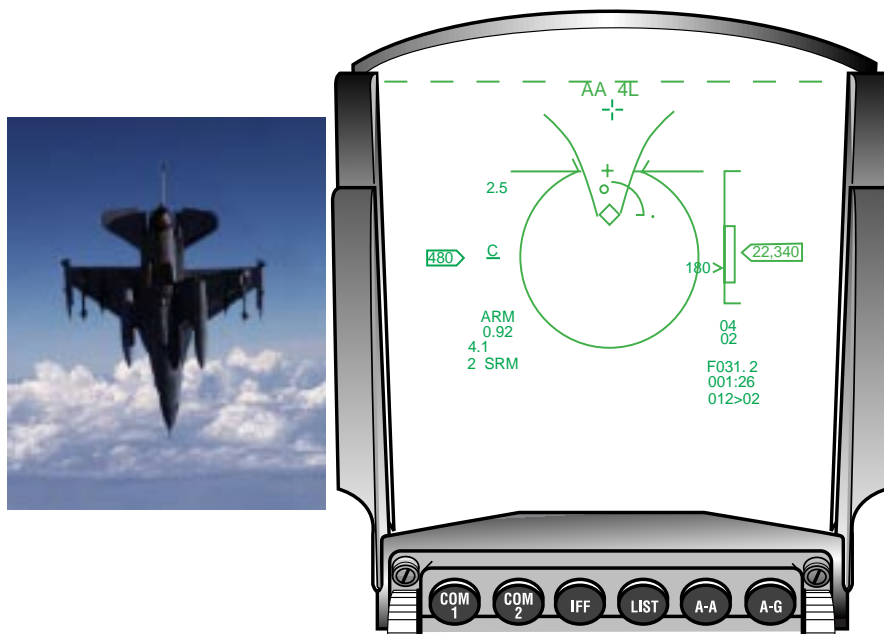

Figure 3-22 Nose-down Wings Level Attitude Awareness Arc

The GHL appears when the aircraft exceeds +/-10 degrees of pitch to enhances attitude awareness in conjunction with the Attitude Awareness Arc.

Target Altitude In HUD (RDP-1361)

The target altitude replaces the ALOW setting on the HUD when the FCR is in an A-A mode and data concerning the bugged target and system altitude are valid. The ALOW altitude setting is moved above the altitude scale (Figure 3-23).

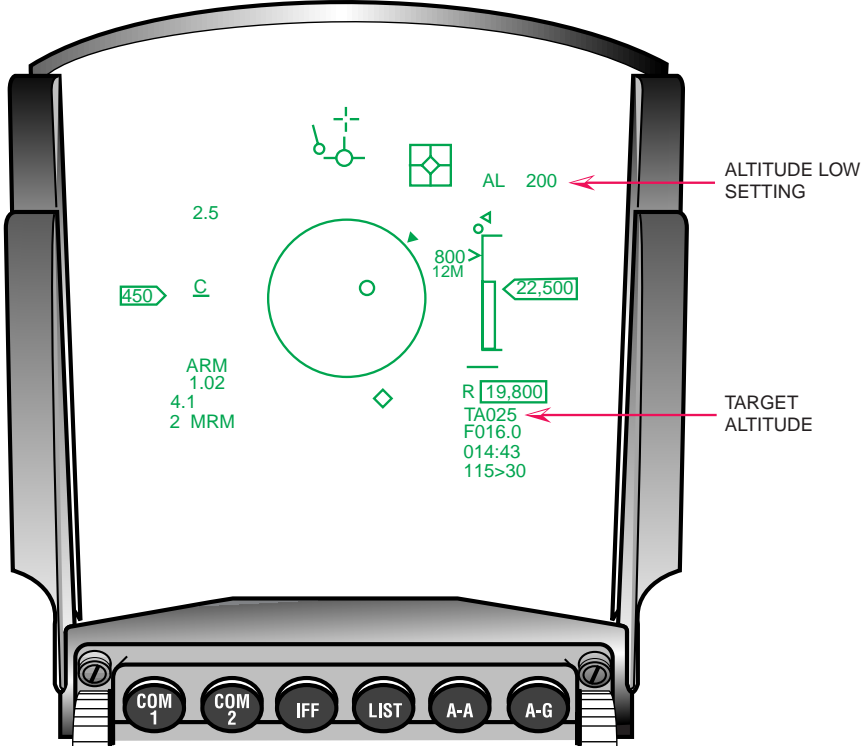

Figure 3-23 Target Altitude Display In MLU HUD

Heads Up Indication Of Imminent Radar Break Track (RDP-1049)

This candidate uses the existing M1 FCR Coast mechanization to provide a head-up indication that the FCR is about to break track. A dashed TD box appears when an imminent break lock condition occurs and the FCR TOI is in the HUD field of view. If the TOI is outside the HUD field of view and a imminent break lock condition occurs, a dashed Target Locator Line (TLL) appears in the HUD.

For clarification, the original Coast mechanization remains unchanged. A dashed TD box appears when a coast situation occurs for the FCR TOI located within the HUD field of view, and "COAS" appears in the target closure rate portion of the Missile Launch Envelope (MLE). If the TOI is outside the HUD field of view and a coast situation occurs, a dashed TLL is displayed, and "COAS" appears in the target closure rate portion of the MLE.

EEGS Improvements: Flexible MRGS (RDP-796)

In the previous HUD OFP, the Multiple Reference Gunsight (MRGS) lines were drawn assuming a target fuselage length of 60 feet. Consequently, the in-range cue that is provided by comparing the apparent target fuselage length with the MRGS line length was only accurate against 60-foot long targets. Therefore, to improve the accuracy of the MRGS in-range indication,

the lines are now drawn assuming a target length that is 1.5 times the entered target wing span. Target wing span can be entered via the DED Manual page (Figure 3-24) or the DTE load.

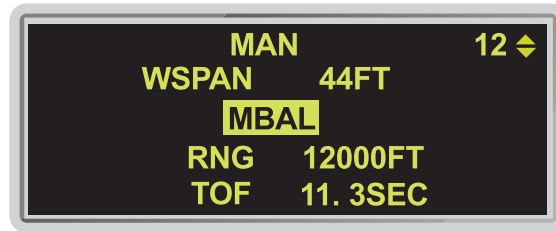

Figure 3-24 DED Manual Page

EEGS Improvements: Clamp MPLs (RDP-798)

The extended range of the PGU-28 round also results in greatly extended Maneuver Potential Lines (MPLs). So, to prevent confusion with the horizon line, the total length of both MPLs plus the T-gap has been limited to a maximum of 100 mils.

Remove Max Range Dot When In Range (RDP-800)

To reduce the possibility of the pilot confusing the max range dot for the Level V piper, the new HUD OFP removes the max in-range dot (Figure 3-25) when the target is 1,000 feet or more inside the maximum range. The max in-range dot reappears when the target has an opening velocity and exceeds the maximum range.

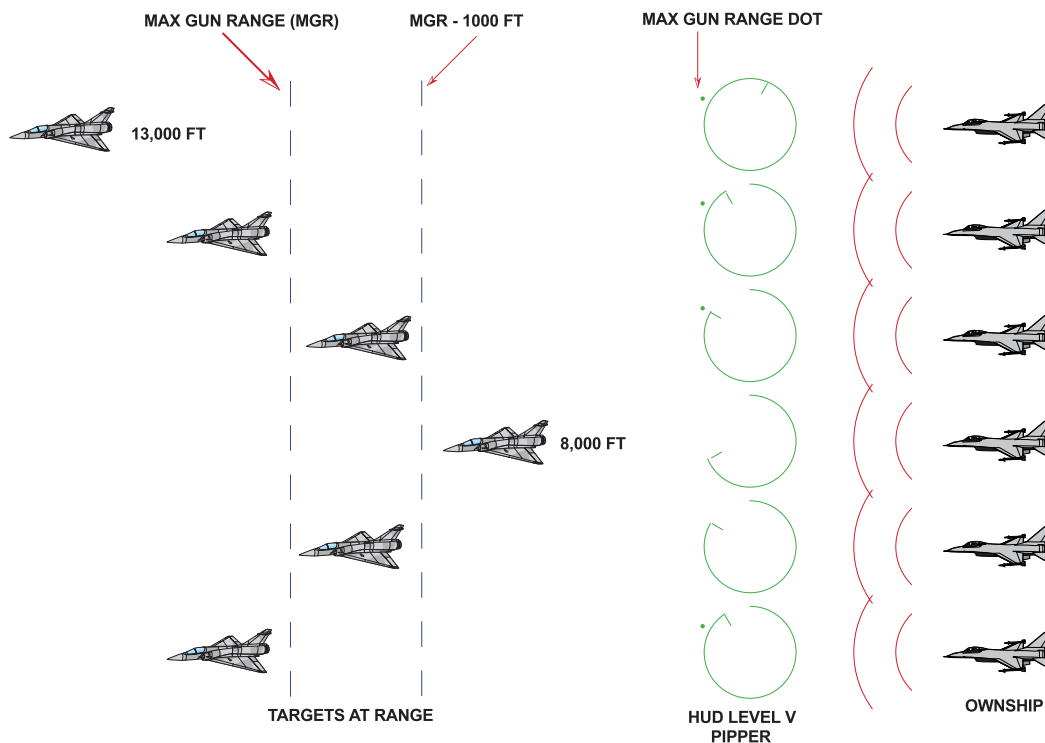

Figure 3-25 Gun In-Range Indications

Continuous FEDS (RDP-910)

M2 adds two pair of Firing Evaluation Display System (FEDS) dots for a total of seven pairs so that with continuous trigger squeeze the FEDS should travel down the EEGS funnel for a minimum of 1.4 seconds. Upon trigger release, the FEDS continue down the EEGS funnel for a maximum time of TF_{MAX1} . TF_{MAX1} is computed by the EEGS algorithm. With a new trigger squeeze, the MMC removes the oldest pair of FEDS dots as they reach TF_{MAX1} and displays a new pair at the top of the funnel (Figure 3-26).

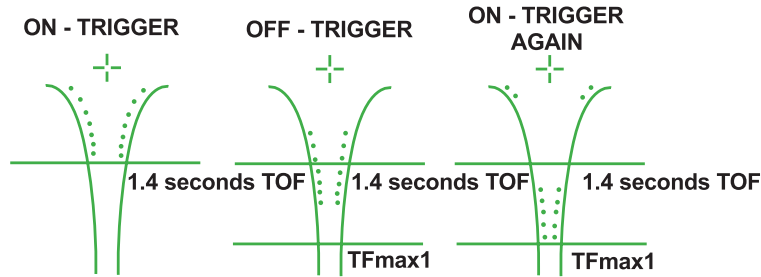

Figure 3-26 EEGS FEDS At Trigger Squeeze And Release

No-Lock Training Mode (RDP-591)

M2 provides the capability to select EEGS Level 2 training while maintaining a radar lock. The level 2 No Lock Training mode is selected via OSB #9 (TNG ON) on the Stores Management Set (SMS) Base page (Figure 3-27).

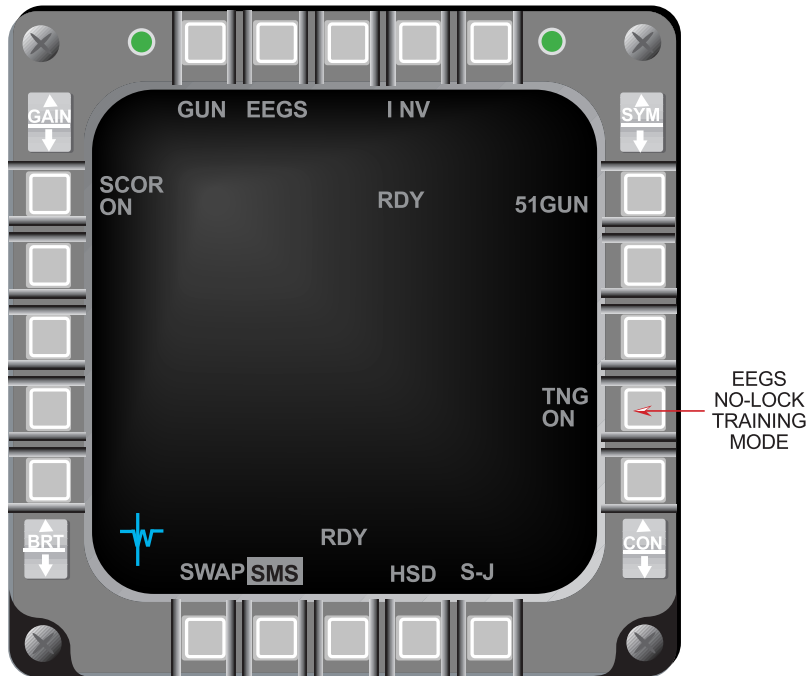

Figure 3-27 SMS Base Page

With No Lock Training selected, the FCR radar is allowed to track the target so that the Bullets At Target Range (BATR) symbol can be computed and displayed. The BATR scoring indication is provided at trigger squeeze. The EEGS display is restricted from transitioning beyond EEGS Level II (no radar lock) as it normally would when the FCR is tracking a target. The EEGS No Lock Training mode consists of Level II symbology with the exceptions that BATR is displayed in place of FEDS and target slant range and target closure range are displayed (Figure 3-28).

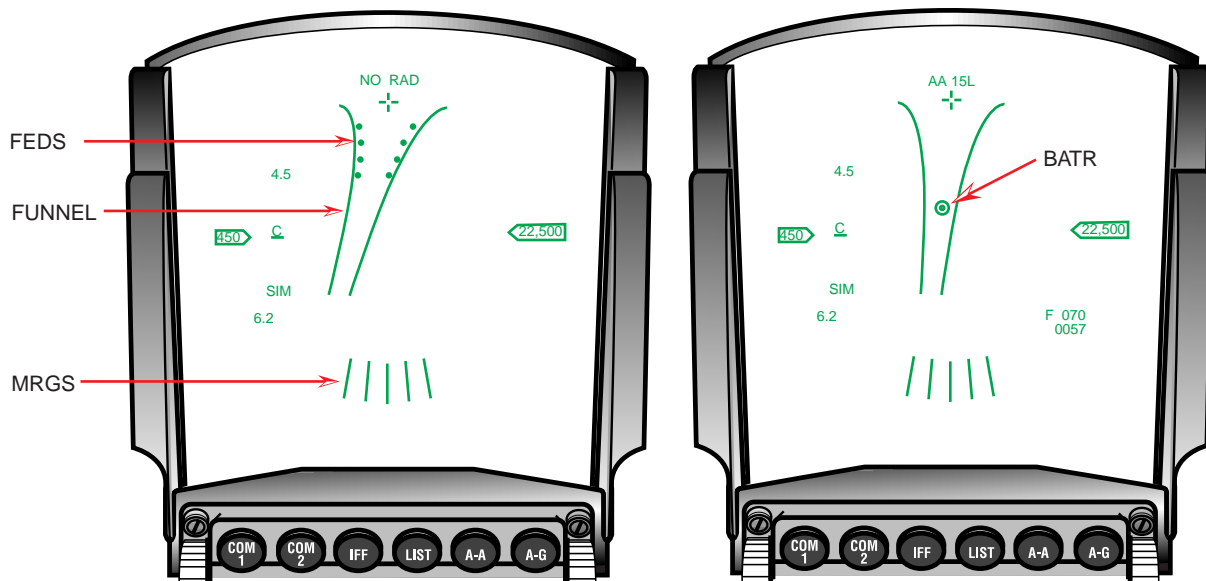

Figure 3-28 EEGS Level II vs. EEGS Level II No-Lock Training Mode

Remech Hands-On Missile Select (RDP-1070)

Depress and Release (D&R) of the Missile Step switch on the sidestick controller provides hands-on selection of a stores station. When in an A-A master mode, D&R of the Missile Step switch for <0.5 seconds selects the next stores station in the rotary (3, 7, 2, 8, 1, 9) with the selected weapon type. The selected station is identified on the SMS Base page by inverse video. Hands-off changes remain the same. Station selection is remembered through MMC power cycles.

When in an A-A master mode and RECCE is not the SOI, depress and hold the missile step switch ≥ 0.5 seconds to select the next missile type in the A-A weapon selection rotary. The avionics system automatically selects the next missile type in the A-A rotary and displays the newly selected weapon mnemonic adjacent to OSB #7 on the SMS Base page. The missile type (SRM, MRM) will also change on the HUD if the new missile is a different type.

There are no changes to weapon selection in the A-G master mode.

AIM-9L/M Bore/Slave Operations (RDP-519)

Once an AIM-9L/M is uncaged and tracking a target, the avionics system no longer automatically cages the missile when changing the Line-Of-Sight (LOS). Depressing cursor-Z or the BORE/SLAVE OSB #19 on the SMS page has no effect on the caging or uncaging of the missile, however, the BORE/SLAVE label is changed. Once the missile is recaged via the uncage

switch or the missile station is changed, the missile is commanded to the LOS displayed on the SMS page.

AIM-9 Auto Acquisition Mechanization (RDP-447)

M2 provides a selectable AUTO Acquisition mode programmable via the DTE. It provides automatic uncaging of the AIM-9 seeker head when the target is within AIM-9 range. It also provides automatic verification that the target LOS is within the selected AIM-9 LOS. If the target is outside the AIM-9 LOS, it automatically slaves the AIM-9 to the target LOS. An AUTO Acquisition mode message “SHOOT” is displayed on the HUD.

The AUTO option is only allowed when the TGP is not the SOI. AUTO is selected on the SMS Base page (Figure 3-29) when in the AAM mode. AUTO is removed from the OSB #19 rotary when the TGP is the SOI. When AUTO is selected and the SOI is moved to the TGP, the missile LOS is automatically changed to SLAVE. Moving the SOI back to the FCR re-enables the AUTO mode. SLAVE and Boresight (BORE) modes are retained through SOI transitions.

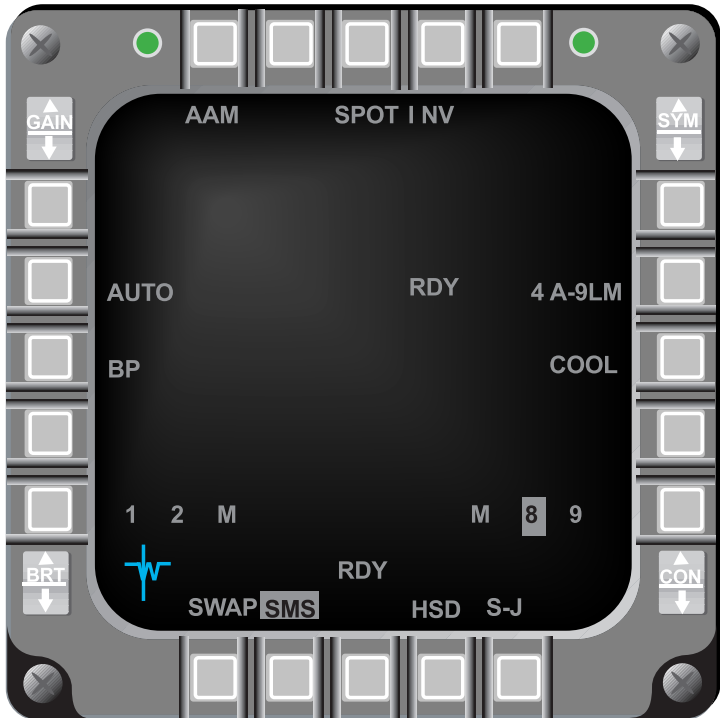

Figure 3-29 SMS Base Page

The avionics system provides 3 verification checks in AUTO when the FCR is tracking a target and the missile is correctly slaved to the target. The first check verifies range of the tracked target is within missile range. When in range, the avionics system automatically commands missile self-track (uncage). The second check verifies the missile is commanded to self-track. The third check verifies the tracked target LOS is within +/- 27 degrees of the missile centerline, and the missile’s LOS is within +/- 1.5 degrees of the tracked target LOS. Otherwise the avionics system commands missile to cage, and then commands the missile seeker head to the tracked target LOS, and then starts the first check again. When all checks are successfully completed, “SHOOT” is flashed on the HUD (Figure 3-30). “Shoot” is displayed as long as conditions allow

the shot to occur and no other higher priority messages exist. “SHOOT” is displayed in the same window as “FUEL” with “FUEL” having priority. The avionics system continues checks and removes “SHOOT” if one of the checks fail.

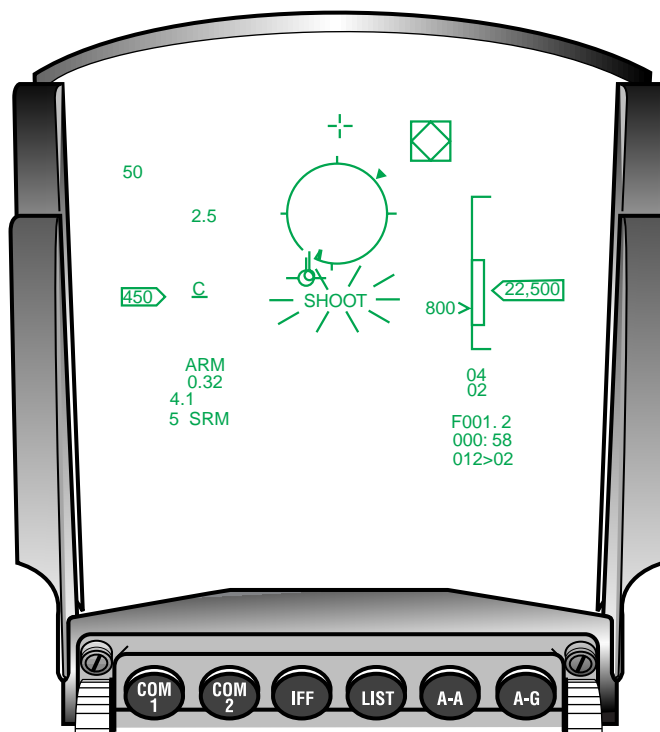

Figure 3-30 HUD Shoot Indication

Weapon Selection Not Affected By Inventory Manipulations (RDP-1503)

In M1 when the SMS inventory was changed, the AIM-9L/M cooling option was replaced with WARM regardless of whether the inventory affected AIM-9L/M missiles.

In M2 when changing inventory not related to AIM-9L/M, the WARM/COOL option remains in its current state. When making an AIM-9L/M related change, the WARM/COOL status is set to WARM. Inventory changes at different stations do not affect the following weapon power settings:

- 1) AMRAAM Telemetry
- 2) AGM-65 Power
- 3) HARM Weapon Power

AMRAAM DLZ Changes (RDP-975); AMRAAM LOFT Cue (RDP-756)

The physical appearance and the terminology defining the AMRAAM DLZ has changed significantly in M2 (Figure 3-31).

- 1) Active Seeker Cue Deleted: The active seeker range cue (small circle) was deleted. Pilots no longer require an active seeker range cue.
- 2) Range Optimum (R_{OPT}) Cue: A small circle (deleted active seeker range cue) depicts the maximum AMRAAM launch range assuming optimum-steering and high quality termination criteria.
- 3) R_{MAX1} Re-designated: The R_{MAX1} part of the DLZ was changed to reflect Range Probability of Intercept (R_{PI}). R_{PI} is the maximum range shot with probable intercept given current steering, aircraft pitch or azimuth changes are not required.
- 4) R_{MAX2} Re-designated: The R_{MAX2} part of the DLZ was changed to Range Turn and Run (R_{TR}). R_{TR} represents the maximum range shot assuming the target performs a "Turn and Run" maneuver at launch.
- 5) R_{MIN1} and R_{MIN2} Deleted: The R_{MIN1} and R_{MIN2} cues were replaced with a single R_{MIN} cue on the AMRAAM DLZ. R_{MIN} is positioned based on R_{MIN1} calculations.
- 6) Range Aerodynamic (R_{AERO}) Cue: The R_{AERO} cue (small triangle) was added to the AMRAAM DLZ on the HUD and MFD. The R_{AERO} cue represents the maximum kinematic range of the AMRAAM and is the longest-range shot that a pilot can take a shot and have a chance of hitting the target. R_{AERO} assumes that the target will not maneuver; that the missile is perfect; and optimum loft conditions are achieved.

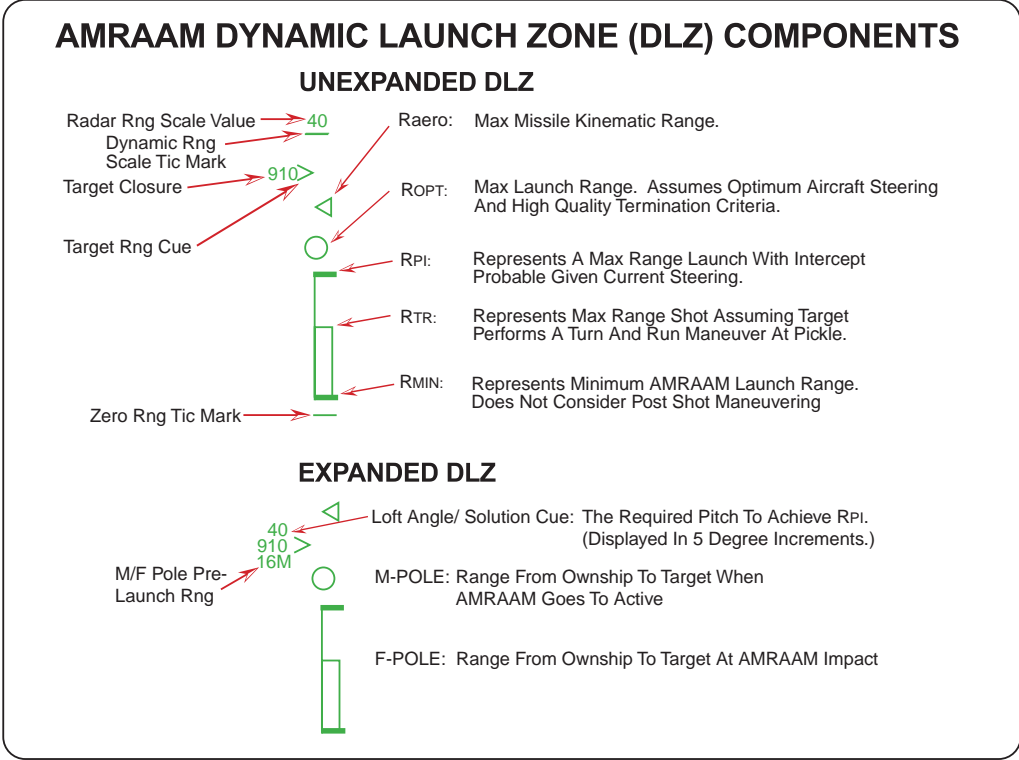

Figure 3-31 AMRAAM Dynamic Launch Zone Components

- 7) AMRAAM Loft Solution Cue: A loft solution cue was added to the AMRAAM DLZ on the HUD and MFD to support the AMRAAM loft launch capability. The loft angle is located above the target closure rate (Figure 3-31). The cue consists of a one or two digit numeric cue representing the climb angle and is removed when the target range is less than R_{PI} . When the DLZ target range cue reaches R_{AERO} a loft angle is provided to indicate the conditions required to achieve an R_{AERO} shot (target range between R_{AERO} and R_{OPT}) or an R_{OPT} shot (target range between R_{OPT} and R_{PI}). For either shot, center the Attack Steering Cue (ASC) in azimuth relative to the Allowable Steering Error Circle (ASEC) and execute a smooth pull-up to the indicated loft angle placing the ASC in the center of the ASEC.
- 8) ASC Limit Cross: An "X" is placed over the ASC on the HUD and MFD when at target ranges exceeding R_{AERO} . The "X" indicates that an AMRAAM loft solution does not exist.
- 9) ASEC/ASC Relationship Redefined: The ASEC/ASC relationship was redefined as a result of the DLZ changes. Figure 3-32 shows this relationship and the steering provided. The type of steering provided is a function of range to the target. Horizontal aircraft steering is provided against targets beyond $1.2 R_{AERO}$. A blend of aircraft and missile steering is provided for target ranges between $1.2 R_{AERO}$ and R_{AERO} . Once inside R_{AERO} , steering provides optimal horizontal and vertical missile steering. When R_{OPT} is reached, the ASEC begins to grow and reaches maximum size (56-mr radius) when the target reaches R_{PI} . At the midpoint of the missile maneuver zone (between R_{TR} and R_{MIN}), the ASEC size begins to decrease and the loft component of missile steering is blended out. When R_{MIN} is reached, the ASEC is minimum size.

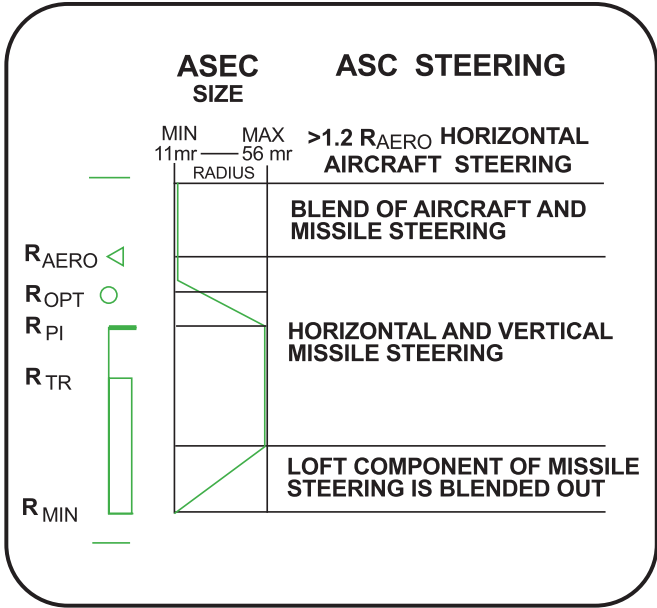

Figure 3-32 ASEC/ASC Relationship

AMRAAM DLZ Transitions (Figure 3-33):

- 1) Unexpanded AMRAAM DLZ Scale: When the current target range is greater than 125% of R_{AERO} , the AMRAAM DLZ is displayed on the HUD and MFD in an unexpanded configuration. On the HUD the upper and lower range scale tics are displayed at their static locations and the radar range scale digital readout is displayed above the upper range scale tic. The remaining AMRAAM DLZ parameters (target range caret, R_{AERO} , R_{OPT} , R_{PI} , R_{TR} , and R_{MIN}) are positioned relative to the upper range scale tic which represents the current radar range scale value and the lower tic that represents zero range.
 The upper and lower boundaries of the unexpanded MFD DLZ are unmarked points located 75% (upper boundary) and 25% (lower boundary) above the bottom of the MFD display area. The upper boundary represents the currently selected radar range scale value and the lower boundary represents zero range. The remaining AMRAAM DLZ parameters are positioned relative to the upper boundary.

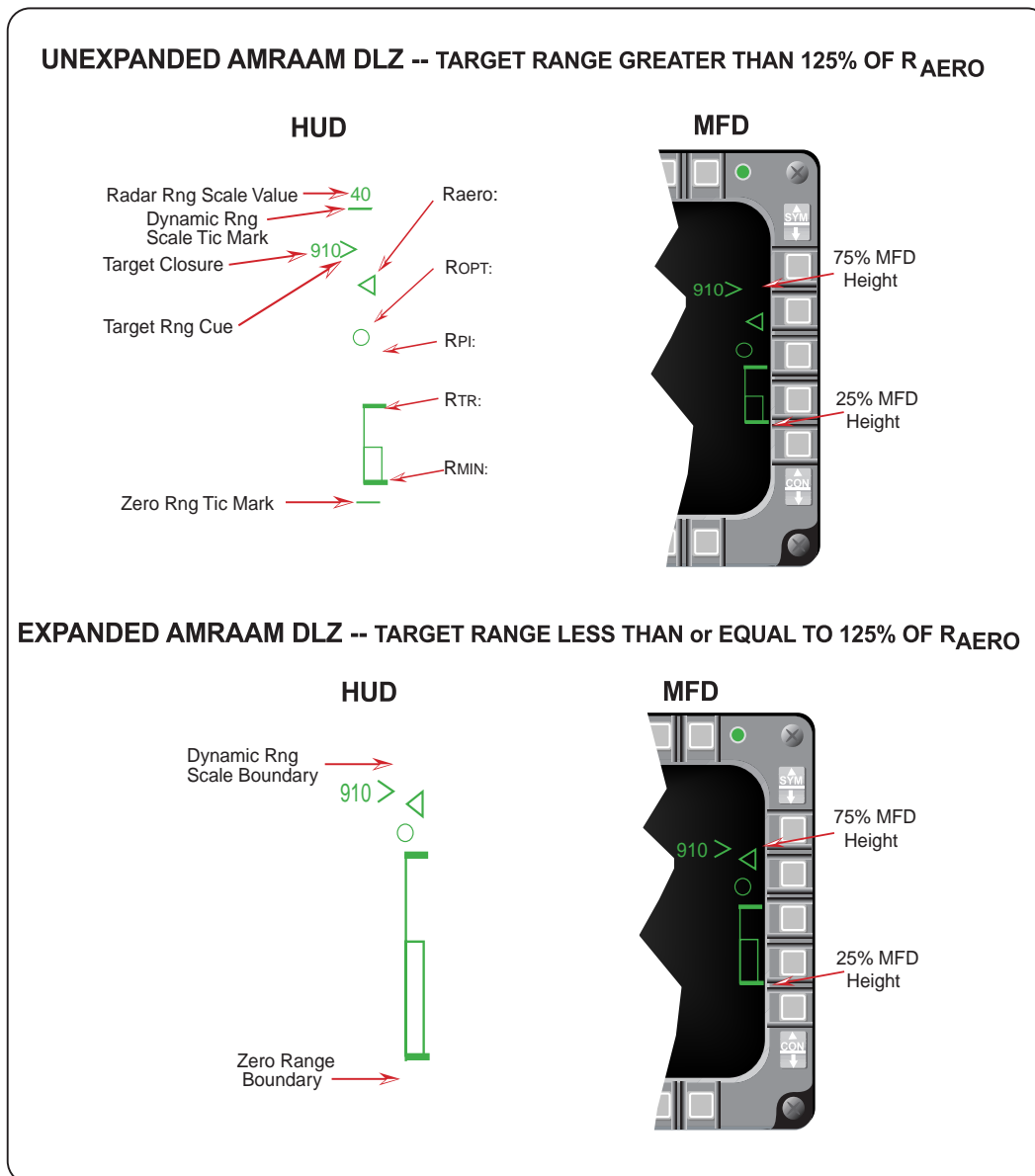

Figure 3-33 AMRAAM Dynamic Launch Zone

- 2) Expanded AMRAAM DLZ Scale: The AMRAAM DLZ transitions to the expanded scale when the target range is less than or equal to 125% of R_{AERO} . The upper and lower range scale tics and the radar range scale are removed from the HUD when the DLZ transitions to the expanded scale. The upper boundary of the expanded range scale on the HUD and MFD are dynamic and represent 125% of R_{AERO} . All DLZ parameters are positioned proportionally to the value of the range scale. However, as target range decreases below 125% of R_{AERO} , the R_{AERO} triangle is always displayed at 80% of the DLZ scale range.

AIM-9 DLZ Transitions (Figure 3-34):

- 1) Unexpanded AIM-9 DLZ Scale: The AIM-9 DLZ received minor modifications to maintain consistency with the AMRAAM DLZ. At target ranges greater than 110% R_{MAX1} the AIM-9 DLZ is displayed on the HUD and MFD in an unexpanded configuration. On the HUD the upper and lower range scale tics are displayed at their static locations and the radar range scale digital readout is displayed above the upper range scale tic. The remaining DLZ parameters (target range caret, R_{MAX1} , R_{MAX2} , R_{MIN2} and R_{MIN1}) are positioned relative to the upper range scale tic which represents the current radar range scale value and the lower tic that represents zero range.

The upper and lower boundaries of the unexpanded MFD DLZ are unmarked points located 75% (upper boundary) and 25% (lower boundary) above the bottom of the MFD display area. The upper boundary represents the currently selected radar range scale value and the lower boundary represents zero range. The remaining AIM-9 DLZ parameters are positioned relative to the upper boundary.

- 2) Expanded AIM-9 DLZ Scale: The AIM-9 DLZ transitions to the expanded scale when the target range is less than or equal to 110% of R_{MAX1} . The upper and lower range scale tics and the radar range scale are removed from the HUD when the DLZ transitions to the expanded scale. The boundaries of the expanded range scale on the HUD and MFD are dynamic and represent 110% of R_{MAX1} . All AIM-9 DLZ parameters are positioned proportionally to the value of the range scale. R_{MAX1} is displayed at 91% of the total scale and remains static at that position as target range decreases below 110% of R_{MAX1} .

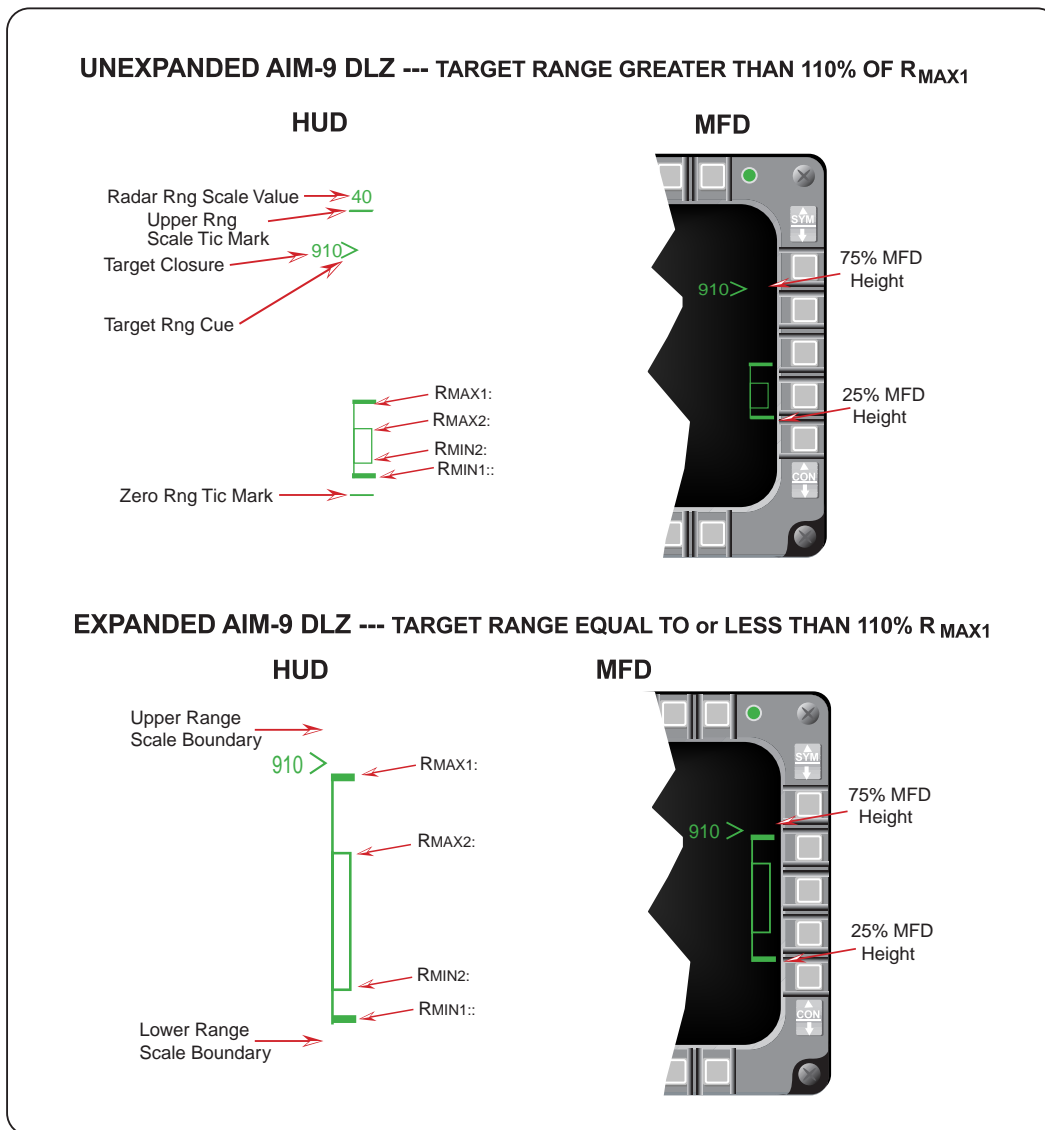

Figure 3-34 AIM-9 Missile Dynamic Launch Zones

AMRAAM Impact Remechanization (RDP-1238)

M2 displays the MFD target tail symbol when a slave launched AMRAAM has been launched against the target. The tail symbol on the target flashes when the missile of interest goes active. When any missile launched against a target is predicted to have impacted the target, the missile impact indication (X) is displayed over the target. The tail symbol only flashes if the missile went active before impact (Figure 3-35). The missile impact indication is displayed for 13 seconds (8 steady and 5 flashing).

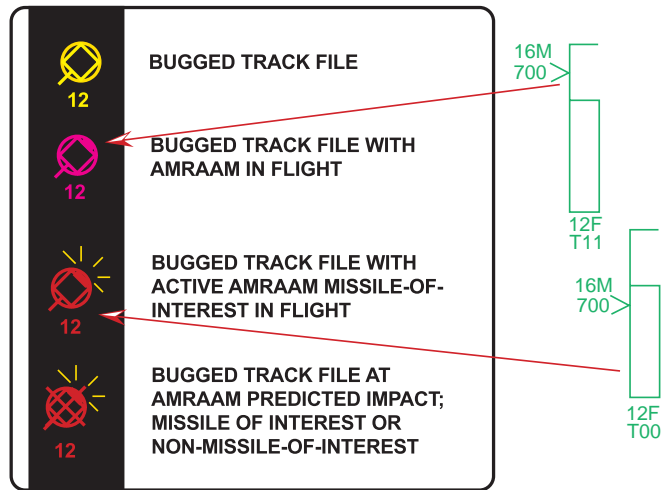

Figure 3-35 MFD Target Symbology With AMRAAM Inflight

If multiple AMRAAMs are launched against a target and the first missile’s time remaining counts down to zero, an “X” is placed over the target symbol. If the missile of interest does not go active prior to the first missile’s impact time, the time to active (A##) is displayed as the time remaining since the missile of interest is not yet active.

An (X) is placed over the target symbol when any AMRAAM launched against the target times out to indicate missile impact. The “X” remains for 13 seconds (8 steady, 5 flashing). If another missile launched against the same target times out before the 13 seconds, the 13 seconds reinitializes for the second missile (Figure 3-36).

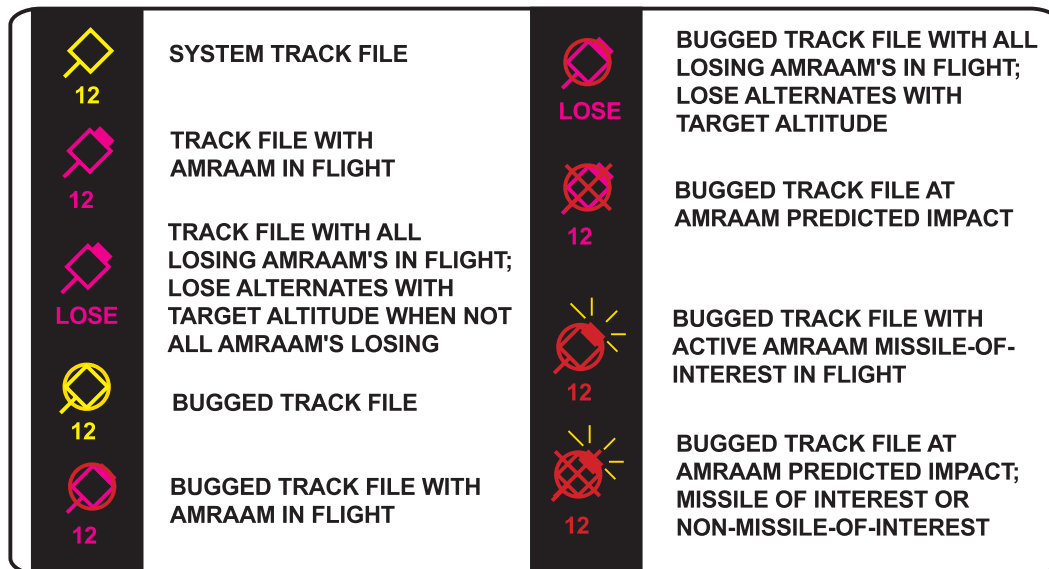

Figure 3-36 MFD Air-To-Air Target Symbology

The MFD target symbol flashes at 5-Hz when a breaklock is imminent. The rules governing AMRAAM post launch target symbology follow:

- 1) Display of the tail is unchanged. The target and tail flash at 5-Hz when breaklock is eminent.
- 2) Display a flashing tail (3-Hz) when the missile goes active. The target and tail flash at 5-Hz when breaklock is eminent.
- 3) Display of LOSE is unchanged.
- 4) Display a flashing tail (3-Hz) with missile impact cross (X) to indicate active missile impact. The target and tail flash at 5-Hz when breaklock is eminent. The missile impact cross is displayed statically for 8 seconds.
- 5) Eight seconds after missile impact: flash "X" at 5-Hz; flash tail at 3-Hz if missile is active; flash target, tail and "X" at 5Hz if breaklock is imminent.
- 6) Display target, tail and "X" steady to indicate a slave launched non-active missile impact. Target and tail flash at 5-Hz and "X" steady when breaklock is imminent.
- 7) Eight seconds after a slave launched non-active missile impact, "X" flashes at 5-Hz. Flash target, tail and "X" at 5-Hz if breaklock is imminent.

New AMRAAM Versions (RDP-645)

M2 incorporates AIM-120B and ITVB (Integration Test Vehicles for AIM-120B) into the SMS inventory. The controls, displays, and symbology for the AIM-120B (store mnemonic A120B) are basically the same as for the AIM-120A. The store mnemonic for the B missile ITV is ITVB. The Dynamic Launch Zone (DLZ) for AIM-120B is the same as for the AIM-120A; however, the performance of the AIM-120B differs from the performance of the AIM-120A.

The AIM-120B is selectable as a unique missile type. The selection of weapon type is modified such that when the last missile of the current type is launched, the aircraft will select a new weapon type that is of the same category (short vs. medium range) if possible.

The A120B mnemonic was added at OSB #7 on the SMS menu-driven Data Entry page (Figure 3-37). The ITV mnemonic was moved from OSB #7 to OSB #9 and changed to ITVA. ITVB was added at OSB #10. The target size mnemonic was moved from OSB #17 to OSB #18 on the SMS Base page.

The AIM-120's and ITV's are loaded on LAU-129 (MRL) and LAU-129 (MRLW).

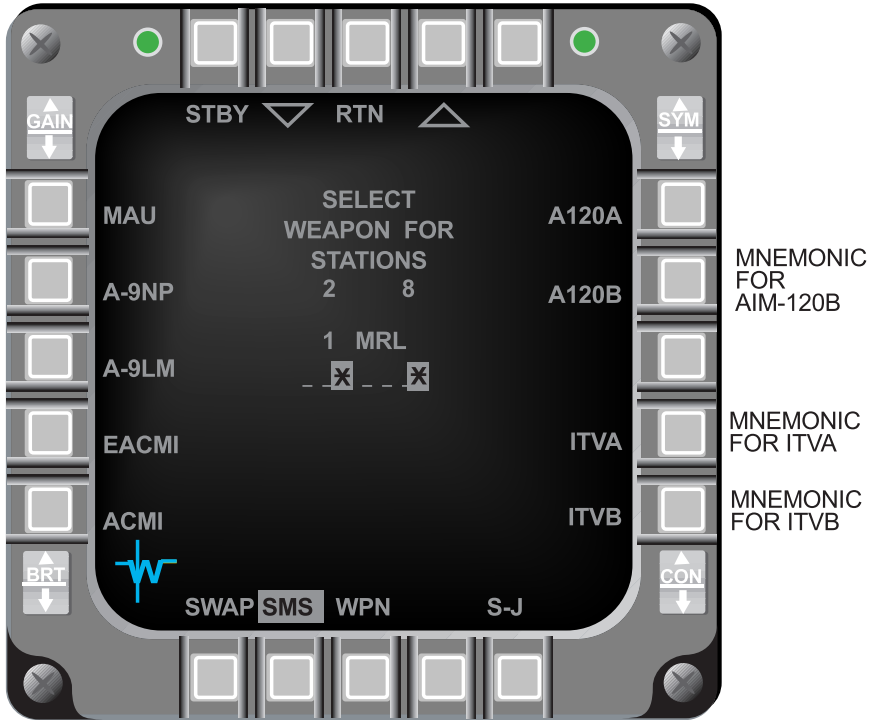

Figure 3-37 New AMRAAM Mnemonics On The SMS Inventory Entry Page

AIM-120 Active Range Indications (993)

Tactical information displayed by the AIM-120 DLZ has been improved. Both A-Pole (ownership to target range when the AMRAAM goes to the Medium PRF (MPRF) mode) and F-Pole (ownership to target range at missile impact) ranges were added to the DLZ (Figure 3-38).

A-Pole or F-Pole range indications, for the missile on the rail, were added to the DLZ below the Target Range Cue caret and Closure Rate indication. Indications are in NM with an M suffix for A-Pole (A is not used to avoid confusion with AMRAAM active indications) and an F suffix for F-Pole.

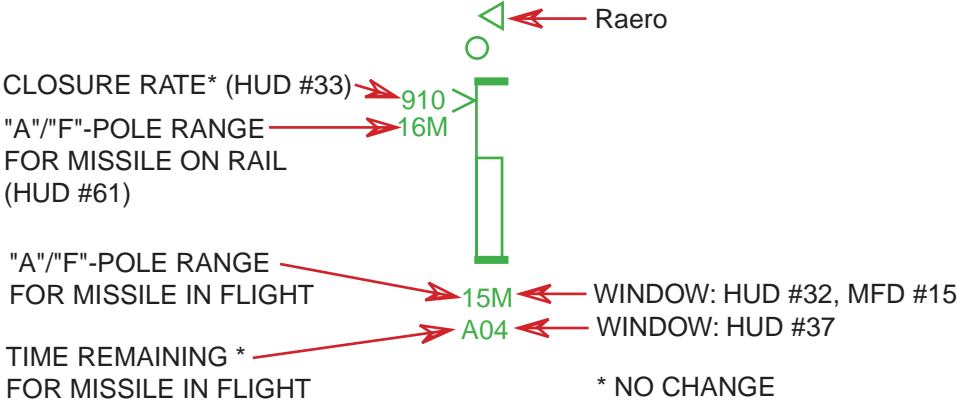

Figure 3-38 AMRAAM DLZ With Active Range Indications

A-Pole or F-Pole range indications for the missile in-flight are added immediately below the DLZ. These indications are for current conditions and will update as the target maneuvers. If the in-flight missile is losing, this display is blanked. This HUD window was previously used to show missile-on-the-rail time-remaining indications.

Time remaining indications for the in-flight missile with the longest time until impact against the bugged target is still displayed in the second field below the DLZ. A prefix identifies the time remaining as follows: T - time until impact, A - time until active, M - time until MPRF, and L - losing missile time until termination.

AIM-120 Launch Against Marginal Track Indications (RDP-986)

This change allows an AMRAAM launch sequence to continue if targeting data (e.g., angle, range, velocity, etc.) become invalid between the time the weapon release button is first depressed and the missile comes off the rail. Normal operation of an AMRAAM launch is not affected by this change.

Marginal FCR track conditions could occur if the target goes into the notch or radar jamming is present. Launch cannot be initiated unless valid targeting data are available; a launch command is ignored when these elements are invalid. However, if an AMRAAM launch is already in progress when data elements become invalid, the last valid data is frozen for use in completing the launch.

AMRAAM Burn (RDP-964)

To prevent missile damage when an AMRAAM is physically loaded on a station with the SMS inventory indicating an AIM-9 missile, the avionics system will fail the station and set the weapon status to Malfunction (MAL).

Flight members need to select different AMRAAM missile ID numbers in order to deconflict missile data link and missile radar frequencies. The missiles receive their ID assignments in the order launched (Table 3-1). The ID sequence is based on the ID number selected on the SMS Control page OSB #17 (ID).

Table 3-1 AMRAAM Missile ID Assignment

ID NO. SELECTED	MISSILE ID ASSIGNMENT
1	6-5-8-3-6-5-8-3
2	7-4-1-2-7-4-1-2
3	2-1-6-5-2-1-6-5
4	3-8-7-4-3-8-7-4

LOSE Cue In HUD Remechanization (RDP-1162)

The MMC provides post launch cues for each AMRAAM that has been slave launched against a system track file. The cues are based on missile launch status, the phase of the missile flight, and when impact on the target is predicted. When target impact is not predicted, the MMC provides LOSE indications on the HUD and MFDs. When all AMRAAM missiles launched against the Target Of Interest (TOI) are in a LOSE condition, "LOSE TOI" is displayed in the middle of the HUD (Figure 3-39). "L##" is displayed under the DLZ, where "##" is the time until termination for the missile of interest, and "LOSE" alternates with the target altitude under the TOI target symbol on the MFD. If any missile launched is predicted to hit the TOI, "LOSE TOI" will not be displayed. When all AMRAAM missiles launched against a particular target other than the TOI are in a lose condition, "LOSE" is displayed in the middle of the HUD and "LOSE" alternates with target altitude under the target symbol on the MFD. "LOSE TOI" has priority over "LOSE" in the HUD.

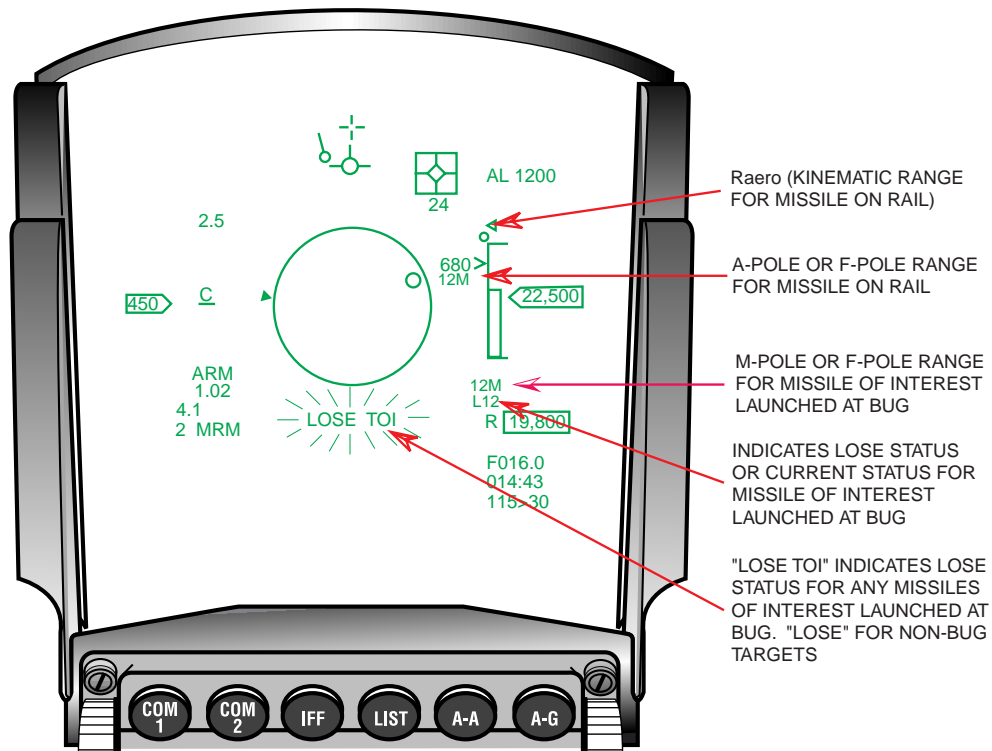

Figure 3-39 HUD AMRAAM LOSE Cue

THIS PAGE INTENTIONALLY LEFT BLANK

SECTION 4 - AIR-TO-GROUND

This section introduces the following Air-to-Ground enhancements:

- LANTIRN Targeting Pod FLIR Interface
- Targeting Pod TV
- Attitude Advisory Function (AAF)
- Generic RECCE Pod II
- BAF RECCE Upgrades
- New Strafe Pipper/Reticule
- Maverick Missile Launch Envelope (MLE)
- Maverick Video Initiation
- EO-VIS Auto SOI Sequence
- HARM
- Mark-84 Transonic Algorithm
- Update CBU-87 Algorithm

LANTIRN Targeting Pod FLIR Interface (RDP-864)

The Block 40T5 generic Targeting Pod (TGP) capability is incorporated into the M2 production tape. The targeting pod contains a passive Infrared (IR) sensor that can track A-A and A-G targets. Tracking techniques include Point Track (based on a high-contrast edge), Area Track (based on intensity levels at various points in the video), and Computed Rates Track (based on the last known angular rate of change for the target). The TGP operates in NAV, A-A, or A-G master mode. The TGP has: two optical Fields of View (FOV), wide (+/-6 deg.) and narrow (+/-1.7 deg.); one electronic expansion (EXP) FOV (0.69x0.69) when selected; two IR polarities (White Hot and Black Hot); and a TV sensor option, plus a variety of brightness and contrast controls.

The TGP has a laser ranger that can be fired at a target for very accurate ranging data. For stationary targets, the TGP can compute a range using angle rates. The laser can be either a low intensity “eye-safe” training laser (indicted by a T) or high accuracy combat laser (indicted by an L). The appropriate character is displayed near the bottom of the TGP format.

WARNING

The combat laser can cause eye damage out to 12 miles.

Control of the TGP is available both hands-on and hands-off. For hands-on control the TGP must be the SOI. Hands-off controls are via the MFDs TGP Base page, the A-A Mode Menu page, the A-G Mode Menu page, and the TGP Control page.

Selecting the TGP mnemonic on the Master Format Menu page will access the TGP Base page. The TGP OFF page is displayed if there is no power applied to the targeting pod. Power is applied to the targeting pod by placing the right Hard Point (HDPT) switch on the sensor power panel to the RIGHT HDPT position. When power is first applied, the TGP is placed in Standby (STBY) mode while the system cools and “NOT TIMED OUT” is displayed in the upper center of the TGP Base page. After the Forward Looking Infrared (FLIR) system has cooled, “NOT TIMED OUT” is removed from the display and the pod transitions to the commanded submode (A-G, A-A or STBY). The pod FLIR sensor normally takes 8 to 10 minutes to cool.

There are four LANTIRN TGP pages: OFF, Base (A-A, A-G), Control (CNTL) and Mode Menu. The TGP Operational Flight Program (OFF) ID is displayed on the DED OFF page 3 only after TGP time-out.

LANTIRN TGP Modes:

The TGP supports the following five modes:

- 1) Off (OFF)
- 2) Standby (STBY)
- 3) Built-In-Test (BIT)
- 4) Air-To-Ground (A-G)
- 5) Air-To-Air (A-A)

The TGP OFF page (Figure 4-1) is displayed when the right HDPT switch is OFF, or the TGP is not communicating on the MUX Bus. These conditions are indicated by the “TGP OFF” mnemonic in the center of the MFD.

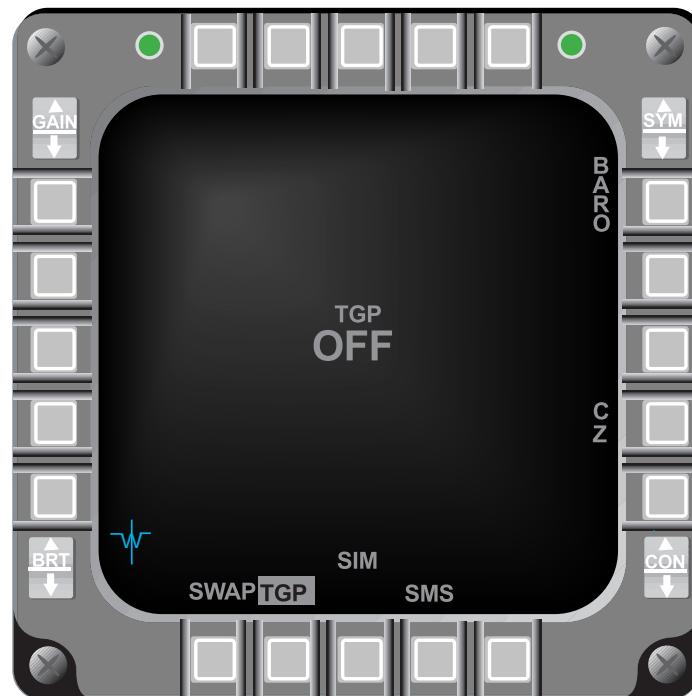

Figure 4-1 TGP OFF Page

The TGP Built-In Test (BIT) mode is accessed from the MFDs Test Format page. After completing the BIT, the TGP returns to the last commanded mode.

During BIT, the TGP provides the following servo checks:

- 1) FOCUS: Image focus changes and then returns to normal
- 2) FOV: FOV changes from WIDE to Narrow (NARO) to Expand (EXP)

- 3) Gimbals: LOS moves to the gimbal limits
- 4) Roll/De-roll Gimbal: Roll gimbal spins nose of TGP for 2 revolutions each direction; then spins target detector assembly for 2 revolutions
- 5) Video Patterns: Several video patterns are displayed to check symbology generation
- 6) Laser: If the laser is armed when bit is initiated, the TGP fires in the 1.54 micron training mode inside the TGP; if the laser is not armed, only the laser electronics are checked

LANTIRN TGP Base Page:

The TGP Base page (Figure 4-2) is accessed via the Master Format Menu page.

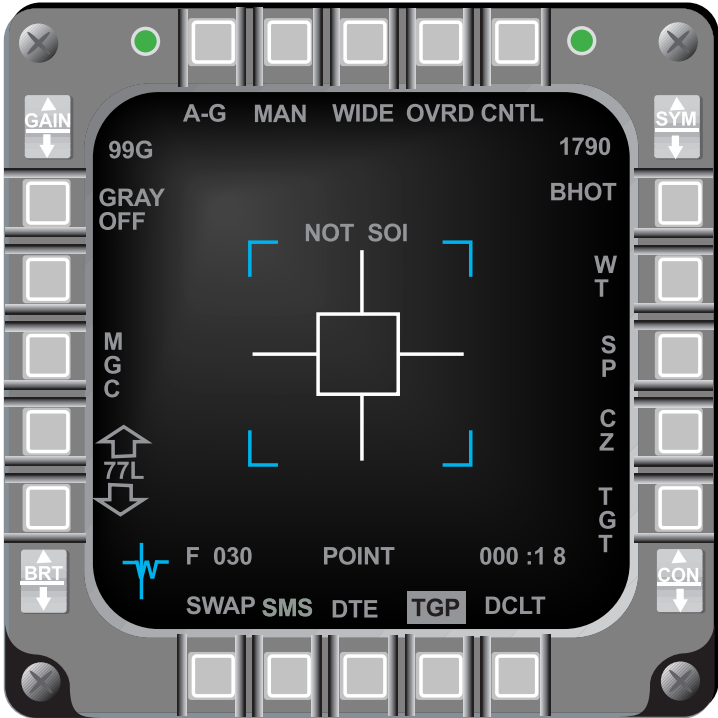

Figure 4-2 TGP Base Page

- 1) TGP Operating Mode (OSB #1): Displays the current operating mode and the OSB accesses the Mode Menu page. Operating mode selection is Master mode dependent; for the A-A Master mode, the TGP may be in A-A or STBY; for the A-G Master mode, the TGP may be in A-G or STBY; and for the NAV Master mode, the TGP may be in A-A, A-G, or STBY.
- 2) Manual (MAN) Submode Select (OSB #2): Provides manual designation, track, hand-off to AGM-65D/G weapons, and laser designation for self-contained laser guided bomb deliveries.
- 3) FOV Select (OSB #3): Displays the current FOV and the OSB toggles between WIDE, NAROW and EXP. With WIDE selected, the narrow FOV indicator is dis-

- played. The FOV can also be changed hands-on by making the TGP the SOI and Depressing and Releasing (D&R) the pinky switch to toggle the options.
- 4) Standby Override (OVRD) Select (OSB #4): Commands the TGP to STBY mode and “OVRD” highlights. With OVRD highlighted, “STBY” is displayed at OSB #1 for all Master modes.
 - 5) Control Page Select (OSB #5): When selected “CNTL” highlights and displays the Control page.
 - 6) Radar Altitude: Radar altitude is displayed above the OSB #6 mnemonic.
 - 7) Display Polarity Select (OSB #6): Alternates between White-Hot (WHOT) and Black-Hot (BHOT) or WHOT, BHOT, and TV depending on which TGP is loaded. With BHOT selected, hot objects appear as black on the display; with WHOT selected, hot objects appear white.
 - 8) Tracking Polarity Select (OSB #7): Alternates between Neutral Track (NT) and White Track (WT) or NT, WT, and Black Track (BT) depending on which TGP is loaded. NT allows both white and black targets to be tracked; with WT selected, only white targets are tracked.
 - 9) Snowplow (SP) Sighting (OSB #8): When selected the TGP is slaved to ½ the selected FCR range until the selected waypoint is ground-stabilized via TMS forward. “SP” is highlighted when selected.
 - 10) Cursor Zero Select (OSB #9): Removes previous adjustments made to the initial cursor position.
 - 11) Sighting Point (OSB #10): Provides the following sighting options and cursor position features:
 - a) STP/TGT – Steerpoint and target direct aim point sighting
 - b) OA1/OA2 – Offset aim point sighting
 - c) IP – Visual initial point sighting
 - d) RP – Visual reference point sighting
 - 12) FLIR Manual Level Adjust (OSB #16-#17): Decreases/increases the intensity level when Manual Gain/Level Control (MGC) (OSB #18) is selected. Video level shifts the video range.
 - 13) Manual/Auto Gain Select (OSB #18): Alternates between Manual Gain/Level Control (MGC) and Automatic Gain/Level Control (AGC). With AGC selected, the level adjust gain label (OSB #16-#17) is removed and gain/level is controlled automatically.
 - 14) Gray Scale Select (OSB #20): Alternates between GRAY ON and GRAY OFF. With GRAY ON selected, the gray scale is displayed across the bottom of the display.
 - 15) GAIN Control (GAIN Rocker): Increases/decreases the gain when Manual Gain is selected (OSB #18)
 - 16) Time to Steerpoint/Release/Impact: Time to steerpoint, release, or impact is displayed in the lower right corner of the TGP page depending on the master mode and whether a weapon has been released. In NAV master mode, this display indicates time to steerpoint. In A-G master mode, this display indicates time to weapon release, then displays the estimated time until impact.
 - 17) SPI Range: The SPI range is displayed in the lower portion of the TGP format. If the range is determined by the TGP laser, an L precedes the range. If the TGP

determines the range, a T precedes the range. If any other sensor provides the range, only the range is displayed.

- 18) Situation Awareness Indicator (SAI): A small square appears on the TGP format indicating TGP LOS in azimuth and elevation. The square is positioned around the center of the display at its azimuth relative to the nose of the aircraft, and its position from the center of the display indicates its elevation with the center representing -90 degrees elevation and the edge 0-degrees. Some examples may help clarify this scheme: The 12-o'clock position at the top of the display indicates 0-degrees relative azimuth and 0-degrees elevation; the 3-o'clock position at the right edge of the display indicates 90-degrees azimuth and 0-degrees elevation. A position half way between the edge and center of the display indicates -45-degrees elevation; and the center of the display indicates -90-degrees elevation. The 6-o'clock position half way between the center and bottom of the display indicates 180-degrees azimuth and -45-degrees elevation. Figure 4-3 shows TGP LOS positions relative to the aircraft.

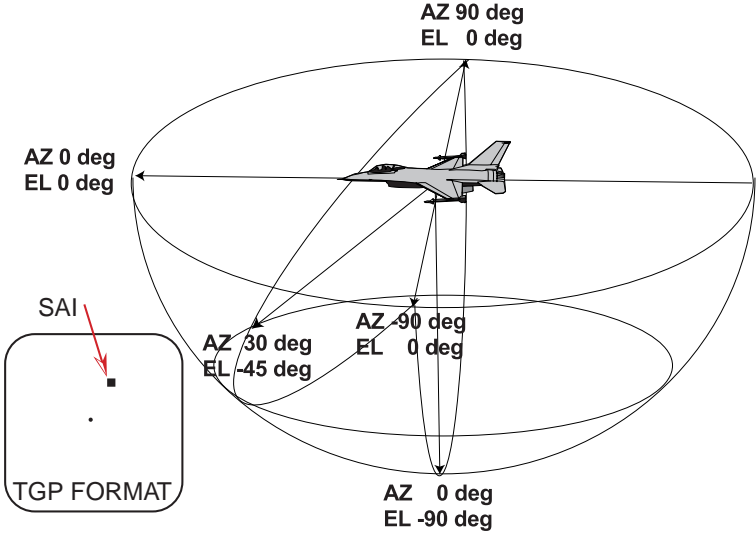

Figure 4-3 TGP LOS Positions Relative To The Aircraft

TGP Control Page:

The TGP Control page (Figure 4-4) allows access to seldom changed functions. The control page is accessed by depressing CNTL (OSB #5). When the Control page is displayed, "CNTL" is highlighted.

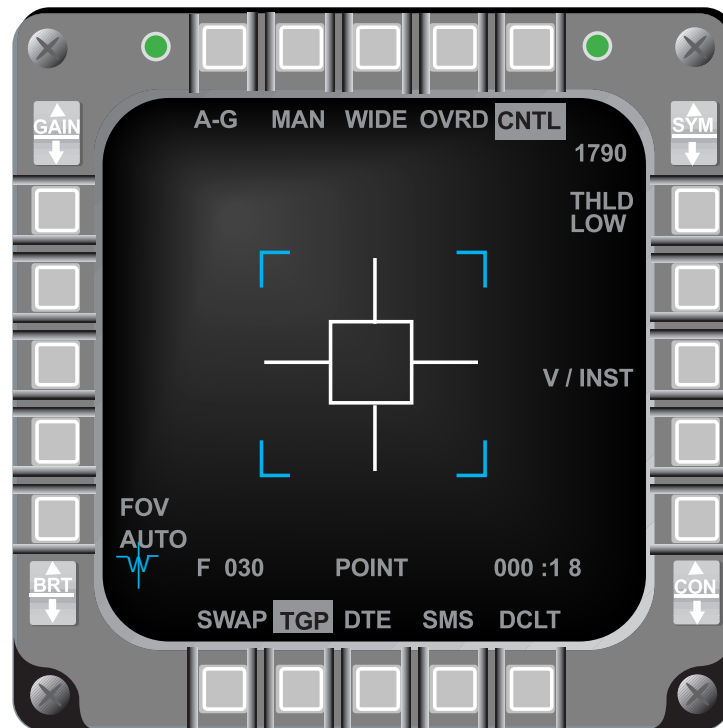

Figure 4-4 TGP Control Page

- 1) Tank Recognition Threshold (THLD) (OSB #6): Selects tank recognition probability threshold choices are LOW, MED1, MED2, and HIGH.
- 2) Video Instrumentation Select (V/INST) (OSB #8): When selected on the ground, the azimuth and elevation of the TGP seeker head are displayed on the Control page
- 3) FOV Select (OSB #16): Alternates between Manual and AUTO. With AUTO selected and target range decreasing, the TGP defaults to WIDE FOV; when the target is too large to track in NARO, it changes to WIDE

TGP Mode Menu Page:

The TGP Mode Menu page (Figure 4-5) provides switching between the TGP modes. Depressing OSB #1 on the TGP Base page accesses the TGP Mode Menu page. The TGP Mode Menu page only displays the modes available for the selected Master mode. In the Nav Master mode, the TGP may be commanded to A-A, A-G, or STBY.

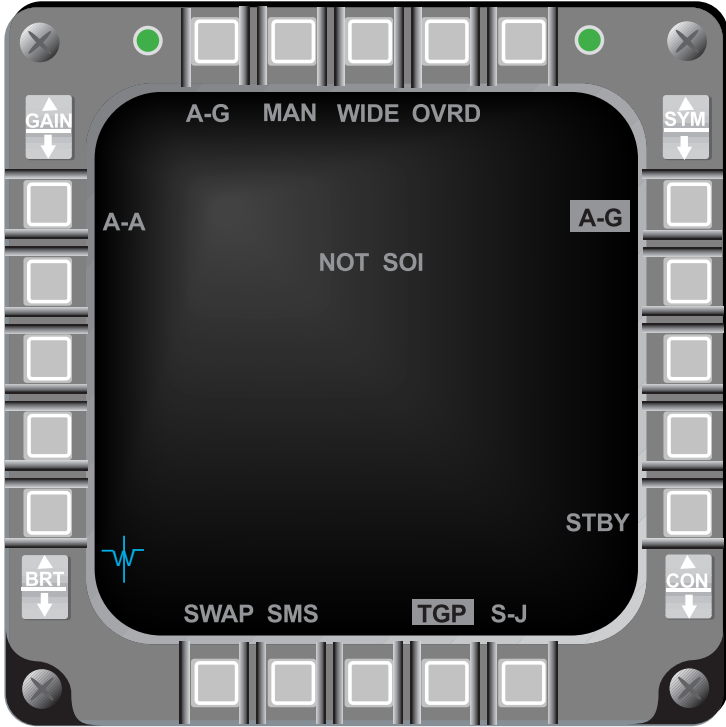

Figure 4-5 TGP Mode Menu Page

TGP Tracking:

The TGP includes processing that performs as an automatic tracker. The tracker operates in three modes: POINT, AREA, and Computed RATES. Tracker mode information is imbedded in the TGP video. During any tracking mode, the cursor is used to reposition the LOS. When cursor inputs stop, the TGP returns to the mode it was in prior to applying the cursors. This allows fine tuning of the tracked point.

POINT Track: The TGP POINT Track mode is capable of tracking single targets. The targets require well-defined edges. An edge in the TGP video exists because of a difference in temperature between the target and its background. When POINT Track is established, a box grows from the center of the crosshairs until the edges of the target are enclosed in the box. "POINT" is displayed below the crosshairs, indicating that track has been established.

Designating with TMS-forward and hold, when the TGP is the SOI, commands AREA track to stabilize the LOS. Releasing TMS-forward commands POINT Track. TMS-aft commands the TGP to break track and return to the SLAVE mode. If the target cannot be POINT tracked because the target does not have sufficient edge detail, the TGP automatically defaults to AREA Track. Once the TGP has changed to AREA Track, it will not return to POINT unless a new POINT Track command is initiated.

POINT Track can be initiated only on objects that appear white in the video image. If track is desired on a black object, the display polarity must be changed via TMS-left or D&R OSB #6 (current polarity). Track on the now-white object can be established. When a white target is tracked and the polarity is changed to black, the track should be maintained unless the LOS is moved.

The TGP tracker continuously updates the tracker box such that, when the aircraft is maneuvered, the tracker box changes to the new viewing aspect of the target. If the target is moving and passes behind another object (e.g., a building), the tracker box may expand to enclose both the target and the object it is passing behind. When the target exits from behind the object, the tracker may reacquire the target or drop track on the target and track the new object. If the latter case occurs, a small cursor input can move the LOS back to the desired target for reacquisition. Which of these conditions occur is dependent on the target, background, and the new object.

AREA Track: The TGP AREA Track mode tracks targets that are not POINT trackable. Large targets, scenes that do not contain targets with well-defined edges, and targets that do not have significant IR signatures are examples of situations where POINT Track might not maintain a stable track. AREA Track may also be used for targets that are point trackable but where AREA Track is desired (e.g., to place the center of the LOS at a particular point). When in AREA Track, "AREA" is displayed on the TGP format below the crosshairs.

AREA Track can be accessed in two ways: 1) TMS forward and hold, or 2) TMS right. AREA Track is commanded as long the the TMS-forward is held. When TMS forward is released, POINT Track is commanded. The benefit of commanding AREA Track is that it stabilizes the scene and makes establishing POINT Track easier. The second method of commanding AREA Track allows AREA Track to be commanded without the TMS being held. TMS-right commands AREA Track only if AGM-65D/G missiles are not selected.

Computed RATES Track Mode: Computed RATES is entered automatically when the POINT and AREA trackers lose target track. This happens most often when the aircraft structure or stores mask the target. The Computed RATES Track mode enables the LOS to remain ground stabilized at the last point tracked. The TGP accomplishes this by using aircraft attitude information and information about the last point tracked. When the masked condition clears, the TGP LOS will be close to the last target tracked. The pilot must manually reacquire the target. "RATES" is displayed below the crosshairs when the TGP is in Computed RATES Track. Computed RATES is not pilot selectable.

TGP Masking: Since the combat mode laser is not eye-safe, even for scattered/reflected energy, it is imperative that the laser beam not strike the aircraft. To accomplish this safety consideration, the TGP determines if it is looking at the aircraft structure or stores. When the TGP LOS is pointed at the aircraft, laser fire is inhibited. The mask zone blocks off the area surrounding the wing tanks on stations 4 and 6 and a LANTIRN navigation pod on station 5L. All other stores are blocked by the wing tanks. Indications of a masked condition includes an "M" on the TGP format next to the L-mnemonic in the bottom right portion of the MFD and "MASK" adjacent to the flight path marker on the HUD.

There is a warning zone outside of the actual mask zone which alerts the pilot that a mask condition is approaching. When in the warning zone, the TGP crosshairs flash and MASK flashes on the HUD.

Navigation:

In the navigation master mode, the TGP A-G mode can be used to determine and slew the SPI as well as use the following functions: TGP FIX, TGP ACAL, TGP Mark, HUD Fix/ACAL/Mark (laser ranging). Additionally, any Nav function that uses radar AGR as a sensor could use the TGP laser range instead.

If the TGP is tracking an A-G target, the target is the SPI by default. In order to maintain the F-16 single LOS concept, if the SOI is moved to the TGP and the pod is commanded to track

or slew, the FCR is sent a break track (RTS) and its LOS is commanded to the TGP LOS. Likewise, if the TGP is tracking and the SOI is moved off the TGP page, and either the FCR is commanded to track or slew inputs are received, the TGP is commanded to break track. If neither the TGP nor the FCR are tracking and the TGP obtains a valid laser range, the location of the SPI is determined using the laser range data.

TGP was added to the sensor rotary on the FIX, ACAL, and MARK DED pages and operates identical to the FCR option. The TGP laser may be used for ranging during a HUD FIX update. FCR AGR is overridden by firing the laser during an update.

TGP A-G Mode:

The A-G mode is used against preplanned targets as an aid for identifying, locating, and acquiring ground targets, and to hand-off targets to Maverick missiles. In the A-G mode, A-G or STBY are the only TGP modes available.

Use of the TGP, during A-G preplanned delivery options (CCRP, LADD, EO-PRE, Peng RDR), to determine the SPI, is similar to navigation operations. With the SOI on the TGP format, the TGP may be commanded to track a target, making it the SPI, or the SPI can be slewed by placing the cursor over the SPI and designating.

TGP laser data can be used during A-G visual deliveries. Pulling the trigger to the first detent fires the laser, pulling the trigger to the second detent latches the laser for 30 seconds (only in CCIP or CCIP Rockets). When dropping LGB's, the laser fires automatically at the entered laser start time and continues four seconds (30 seconds for GBU-24) after the computed weapon impact time.

The TGP can hand-off targets to the Maverick missiles for A-G E-O deliveries. If a Maverick D or G is loaded on a LANTRN compatible launcher, and the TGP is commanded to track, the TGP takes control of the Maverick and hands-off the target to the missile. Once the target is handed-off, the TGP LOS can be slewed to a new target and commanded to track. The TGP again attempts to hand-off the new target to a second Maverick missile.

When the TGP is in the A-G mode with an AGM-65D/G missile on a LANTIRN capable launcher as the selected weapon, a 10-mr box is displayed on the HUD at the target LOS for each target located by the TGP. When the TGP successfully hands-off a target to an AGM-65D/G, the 10-mr box becomes a 10-mr circle. When the TGP determines the target is in range, a tic is displayed on the bottom of the symbol. When two LOSs are established, a small numeric "1" indicates the next to shoot LOS and a "2" indicates the following LOS. When the TGP is in A-G and the selected weapon is other than an AGM-65D/G missile on a LANTIRN capable launcher, a 10-mr box with a 1-mr pipper is displayed representing the target. The TGP Target Locator Line (TLL) is displayed when A-G targets are outside the HUD FOV. The TLL is a 40-mr dotted line extending from the boresight cross at the relative bearing to the target. A number representing total angle off the nose to the target is displayed adjacent to the boresight cross.

In Penguin RDR modes, the TGP is commanded to the target LOS. The TGP Base page displays "TGT" in the sighting point rotary. The FCR Base page changes the sighting point rotary to TGP. Penguin radar modes always move the target independent of the state of the Penguin use rotary. Slewing the TGP with the FCR Penguin use rotary set to waypoint has no effect on the FCR LOS. Slewing the FCR, with the Penguin use rotary set to waypoint does not affect the TGP LOS. However, slewing the TGP with the FCR Penguin use rotary set to target commands the FCR to break track and the FCR LOS slaves to the TGP LOS. Likewise, slewing the FCR with the Penguin use rotary set to TGP commands the TGP to break track and the TGP LOS slaves to

the FCR LOS.

In other non-Maverick visual delivery options like CCIP, DTOS, and Peng HUD, the TGP LOS is slaved to the SPI LOS. If the laser is fired and a valid range is returned, the TGP laser range is used for the SPI calculations rather than the FCR AGR range data.

TGP A-A Mode:

The TGP A-A mode provides visual target identification and tracking of A-A targets. In A-A the TGP is initially commanded to the FCR LOS if the FCR is tracking an A-A target. When the TGP is not the SOI and the FCR is not tracking a target, the TGP LOS is positioned to 0 degrees azimuth and -3 degrees elevation. The TGP can track and maintain an A-A target independent of the FCR LOS, resulting in two A/A TD boxes/TLL's. The FCR and/or AIM-9 missiles can be slaved to the TGP LOS. The AIM-9 missile can be slaved to either the TGP or the FCR LOS. The pilot has the option to fire the laser for accurate ranging data, but it does not override the slant range sent by the FCR. Instead the TGP laser range is displayed immediately below the slant range.

Once the TGP has been commanded to track, the TGP LOS and the FCR LOS are independent. The TGP LOS is shown as a dotted 50-mr A-A TD box in the HUD. If the TGP LOS is outside the HUD field-of-view, a dotted TLL and target angle are displayed. The FCR A-A TD box is a solid 50-mr box.

Although the TGP LOS is independent of the FCR LOS, depressing TMS right (independent of SOI) commands the FCR into ACM boresight along the TGP LOS when the TGP is tracking and the FCR is in ACM.

If an AIM-9 is the selected weapon and is caged in the Slave submode, it is slaved to the LOS of the SOI sensor. Whenever the AIM-9 LOS is within 1.5 degrees of the sensor it is slaved to (correlation), a "C" is placed to the left of the target angle indicator for that sensor.

Targeting Pod TV (RDP-1170)

OSB #6 on the TGP Base page (Figure 4-2) was modified to allow the TGP sensor to be swapped between IR (baseline) and TV when the aircraft is loaded with a TV capable TGP. For IR only TGPs, OSB #6 toggles between WHOT and BHOT; For TV capable TGPs OSB #6 rotates between WHOT → BHOT → TV. OSB #7 selects the tracking polarity. For IR only TGPs, OSB #7 toggles between Neutral Track (NT) and White Track (WT). With a TV capable TGP load, the OSB #7 rotary steps between NT → WT → BT (Black Track).

Attitude Advisory Function (AAF) (RDP-1502)

An attitude advisory is triggered when all of the following conditions exist:

- 1) TGP format is displayed
- 2) TGP mode is A-G
- 3) INS attitude data is valid
- 4) Aircraft exceeds any of these defined attitudes:
 - a) Bank > 75 deg; Pitch < 0 deg.
 - b) Pitch < -20 deg

When these conditions are met, a flashing rectangular box with the double set of words "CHECK ATTITUDE" (Figure 4-6) is displayed on both MFDs (all formats). The attitude advisory is dis-

abled whenever one or more of the four conditions listed above no longer exist. The “Check Attitude” box default color is red and is DTC loadable.

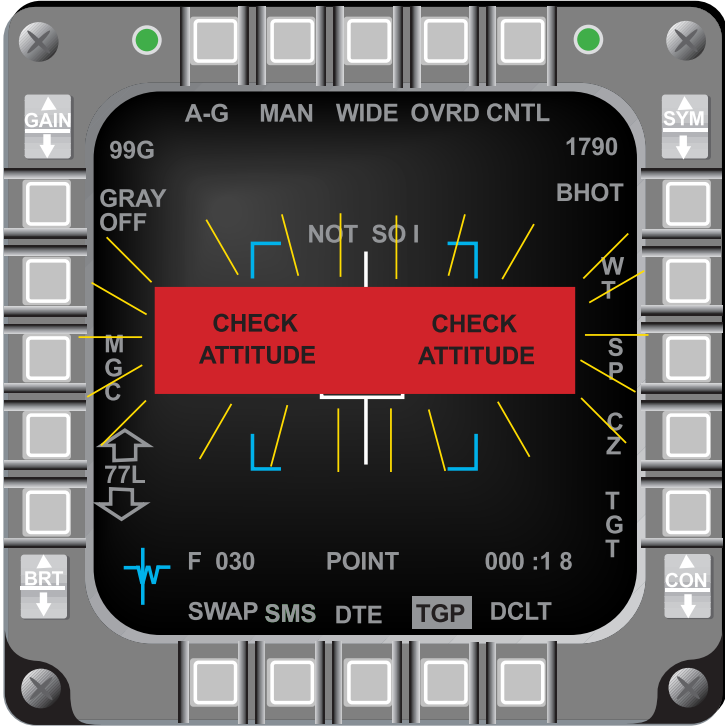

Figure 4-6 Attitude Advisory For MFD Formats

Generic RECCE Pod II (RDP-865)

A new “TEST” button was added to the RECCE Base page at OSB #5 (TEST). Depression of the test button will bring up the RECCE Test page and the labels adjacent to OSB #s 1-4, 6-10 and 16-20 are provided by the RECCE Pod (Figure 4-7). These buttons are then connected to the RECCE Pod via the 1553 Mux Bus and function as commanded by the RECCE pod. Depression of OSB #5 (RTN) on the Test page returns to the RECCE Base page.

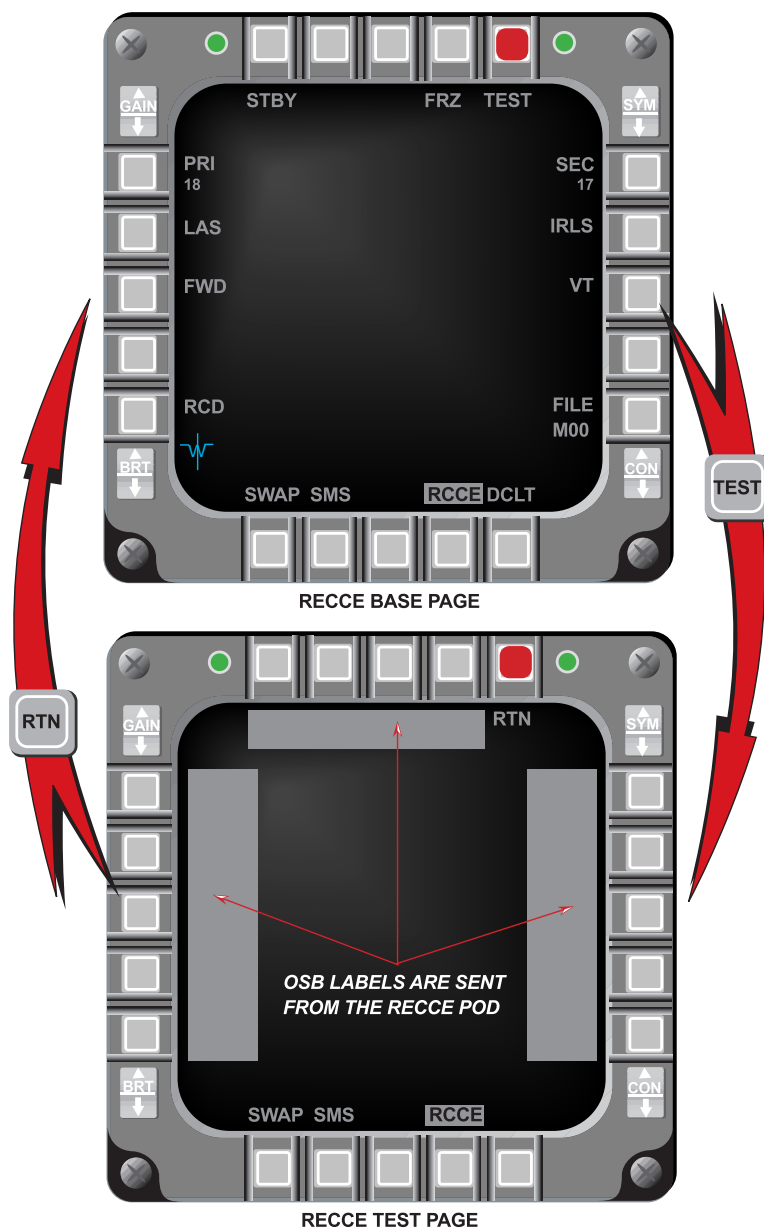

Figure 4-7 RECCE Pod Access Via Test Button

BAF RECCE Updates (RDP-1700)

Based on Belgium Air Force (BAF) requirements, the MMC will pass/set the following interface to the EWMS:

- 1) Additional aircraft attitude (INS) data
- 2) Addition of data for RECCE image marking
- 3) Time-of-day/current time
- 4) Height-Above-Target (HAT) information
- 5) Landing gear status

New Strafe Pipper/Reticle (RDP-592)

M2 provides a new Strafe (STRF) pipper that is suitable for both the PGU-28 long range bullets and the shorter-range M-56 bullets. When in STRF, the avionics system displays a loadable/programmable MFD ammo in-range value for the HUD in-range cue. The SMS page displays the slant in-range bullet data and mnemonic adjacent to OSB #9. Selection/modification of the bullet in-range value is via OSB #9 on the SMS STRF Base page. When no values are entered, initialization bullet in-range values are 12,000 feet for PGU-28 and 4,000 feet for M-56 ammunition.

The new strafe pipper, ranging reticle and associated symbology (Figure 4-8) consist of:

- 1) 50-mr diameter strafing reticle
- 2) 40-mr diameter strafing reticle
- 3) 2-mr diameter in-range cue
- 4) 5-mr length tic to designate slant range
- 5) moving target indices at 3 and 9 o'clock for ground targets
- 6) a bullet track line.

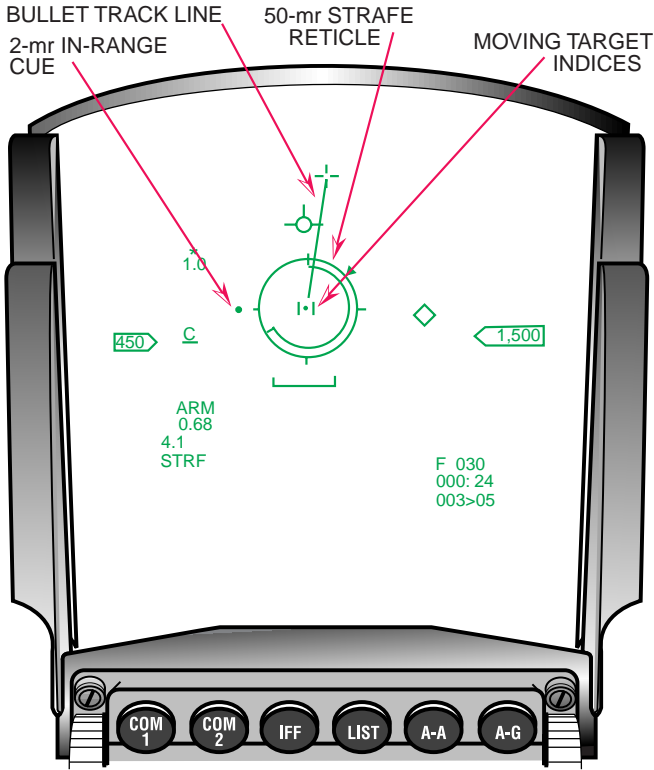

Figure 4-8 HUD Strafe Pipper

The Moving Target Indices (MTI) are roll stabilized and scaled to provide an aiming reference against a ground target moving at 30 knots perpendicular to the LOS. The MTI is limited to 15-mr on either side from the center of the CCIP pipper. The new strafe pipper/reticle is illustrated in Figure 4-9 at various ranges for both the M-56 and PGU-28 bullets:

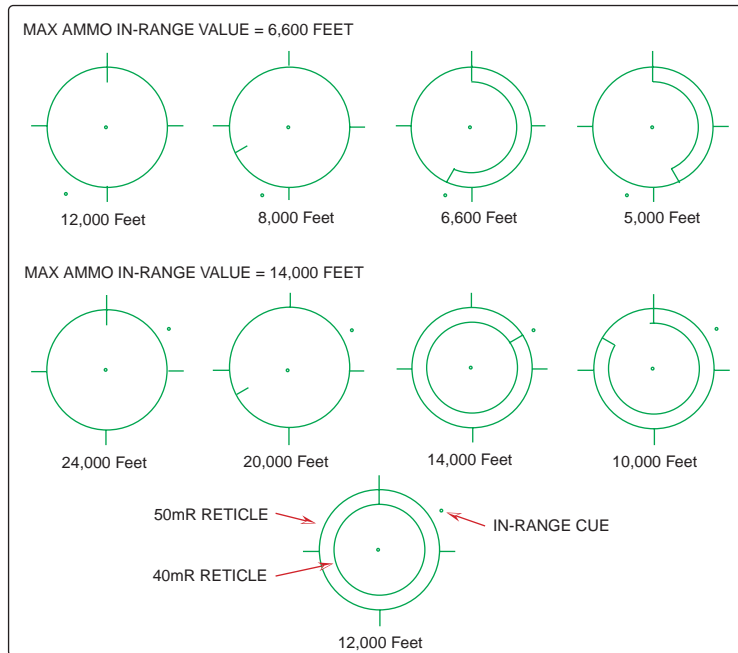

Figure 4-9 Strafe Pipper/Reticle For M-56 And PGU-28 At Various Ranges

Maverick Missile Launch Envelope (RDP-306)

M2 incorporates the Maverick Missile Launch Envelope (MLE) for the Electro-Optic (E-O) modes. An in-range caret is positioned on the HUD and MFD DLZ displays at target range. Aircraft horizontal range to the system target is used for the in-range computations.

The A-G MLE scale is available when all of the following are true:

- 1) Selected weapon is a Maverick A, B, D, or G
- 2) Horizontal range to the target is less than 20-NM
- 3) Target is within +/- 30° of the aircraft X-axis
- 4) INS data is valid
- 5) Central Air Data Computer (CADC) data is valid
- 6) And one of the following are true:
 - a) Submode is E-O Preplanned, or
 - b) Submode is E-O Bore, or
 - c) Submode is E-O Visual post designate

The MLE is computed using aircraft airspeed, Height Above Terrain (HAT), and performance parameters for the selected Maverick. When the weapon station is changed, the Maverick MLE range caret remains referenced to the system target. The missile footprint is displayed as the delta between R_{MAX} and R_{MIN} . The Maverick boresight cross on the MFD E-O WPN page is flashed when the missile determines that the target cannot be properly tracked.

The HUD A/G MLE is a modified CCRP Loft Scale. A number and caret representing the horizontal range to the target in nautical miles moves vertically down the missile footprint scale. When the caret is positioned between the max and min range tics, the missile is in range

(Figure 4-10). A similar A/G MLE is displayed on the MFD E-O Weapon page.

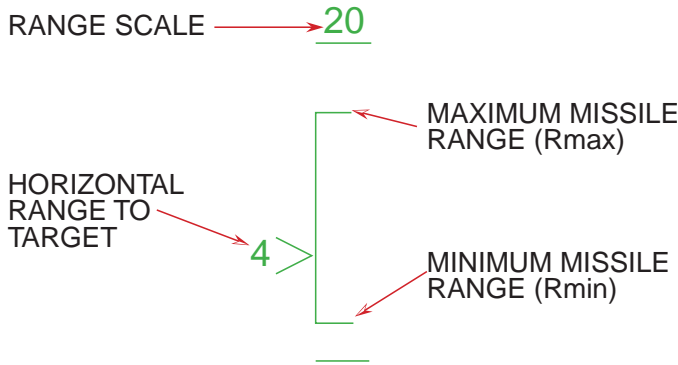

Figure 4-10 Maverick MLE in the HUD

Maverick Video Initiation (RDP-1240)

Maverick video is toggled “ON” and “OFF” when uncage is depressed on the throttle. It is no longer turned on at entry into the A-G mode or after timeout.

EO-VIS Auto SOI Sequencing (RDP-1164)

With the SOI in the HUD and EO-VIS selected, the first TMS up (designate) ground stabilizes the TD box and allows cursor slews to refine the TD box position. A second designate moves the SOI to the WPN format.

HARM (RDP-1200)

The High Speed Anti-Radiation Missile (HARM) (AGM-88) (Figure 4-11) is a programmable, frequency adjustable, air-to-ground, anti-radiation missile that may be loaded on weapon stations 3, 4, 6 and 7, however, it is only flight certified on stations 3 and 7. The HARM is designed to detect and attack enemy air defense systems across the RF spectrum.

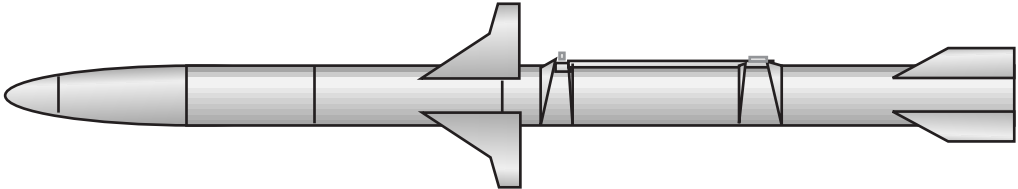

Figure 4-11 High Speed Anti-Radiation Missile (HARM) (AGM-88)

HARM requires a Launcher Avionics Package (LAP), which consists of an Aircraft Launcher Interface Computer (ALIC) installed inside the LAU-118 launcher pylon. The ALIC provides the interface between the weapon and aircraft.

The HARM Test Vehicle (HTV) is a HARM with the warhead replaced by a telemetry package.

DTE Loading of HARM data:

HARM data is loadable from the DTE page via OSB's labeled "ELINT", "INV", "PROF", and "MSMD". The data consists of HARM threat data, stations loaded, selected mode/flight profile, and the threat symbology tables in the DED HARM page and HARM WPN format.

SMS HARM Base Page:

The HARM Base page (Figure 4-12) contains the following unique controls:

- 1) Tertiary Table (TER TBL) OSB #2: Rotaries between TBL0, TBL1, TBL2, and TBL3. TBL0 loads only the selected threat and table. TBL1,2,3 Load the primary threat table and the tertiary table.
- 2) Weapon selection OSB #6: "AG88" is displayed when HARM is the selected weapon, "HTV" is displayed when an HTV is selected.
- 3) Missile Power (PWR) OSB #7: Toggles between PWR ON and PWR OFF.
- 4) BIT OSB #8: Commands BIT at the selected station. Automatic BIT is commanded on all ALIC/HARM stations at power up. Station number is replaced with "F" for failed missiles or "D" for degraded missiles.
- 5) Selective Jettison (S-J) OSB #11: S-J applies power to all HARM loaded stations.
- 6) Gyro Test (GT) OSB #18: Toggles between GT ON and GT OFF. GT is only displayed for HARMs with a telemetry unit (HTVs) and Master Arm in SIM.
- 7) Command-Destruct (CD) Enable OSB #20: Displayed only with Master Arm in ARM or OFF. Turns CD ON. Can only be disabled by an inventory change. HARM Test Vehicles (HTV) can be self-destructed from a ground station when enabled.

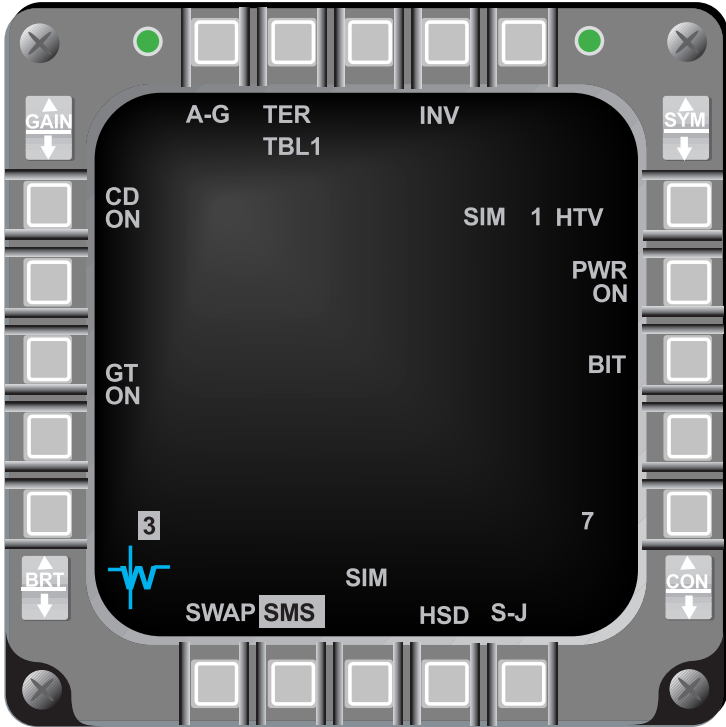

Figure 4-12 SMS Base Page With HTV Selected

DED Pages:

HARM DED pages are used to view, verify, and modify the three threat tables and the five manual threats used for the HARM mission. The threat tables contain either decimal ID's or manual threats. The decimal ID's (0-999) access threat parameters in the ALIC's database. Manual threats are made up of threat parameters transmitted to the ALIC. Both decimal ID's and manual threat parameters allow the ALIC to compute information necessary for successful launches in the various HARM modes. The two HARM DED page types are the HARM Threat Table and HARM Manual Threat pages.

HARM threat tables are accessed by depressing LIST, 0 (MISC), 0 (HARM) on the UFCs when HARM is the selected weapon, or by depressing UFC (OSB #5) on the HARM POS, HAS, or DL Weapon page. HARM is removed from the DED MISC page when HARM is not the selected weapon. Positioning the DCS switch to SEQ from the HARM Threat Table page steps to the HARM Manual Threat page #1. A second SEQ steps to HARM Manual Threat page #2.

The HARM Threat Table page (Figure 4-13) allows changes to the five entries in each of the three threat tables (1, 2, or 3). The INC/DEC switch on the ICP rotaries through the three HARM threat tables. The page consists of the HARM threat table label and the HARM table. The table consists of the threat number (T1-T5) and the decimal ID (0-999) or manual threat designation (MN1-MN5).

HARM TBL1	T1	*206*
	T2	88
	T3	208
	T4	MN1
SEQ=MN2	T5	372

Figure 4-13 HARM Threat Table DED Page

Threats are entered by placing the asterisks around the desired threat code and entering the desired decimal ID (0-999) followed by “ENTR”. Upon entry the asterisks automatically step to the next threat. Manual threats are entered by positioning the DCS to SEQ. MN# is displayed in the threat code ID field to indicate the lowest manual threat available. Manual threats are removed by replacing them with a decimal threat ID.

The HARM Manual Threat pages (Figure 4-14) are divided into the HARM Manual Threat page label with threat number, and the manual threat data entry area. The threat data entry area displays coded words representing threat data for threats 1-6 on page 1 and threats 7-12 on page 2.

HARM TBL1	MN1	23
1 *123.45*	5	12345
2 123.45	6	12345
3 123.45		
4 123.45		PG1

HARM TBL1	MN1	23
7 123.45	11	12345
8 123.45	12	*12345*
9 123.45	ERROR	
10 123.45		PG2

ERROR DISPLAYED
IF DATA ENTRY
ERROR DETECTED

ERROR BLANKED
IF DATA ENTRY OK
OR UNVERIFIED

Figure 4-14 HARM Manual Threat Pages

Word 12 on page 2 is a checksum value that must be entered any time manual threat words are changed. When any value other than “0” is entered, the system checks for the correct entry of the first 11 words. “ERROR” is indicated on page 2 when the values of the 11 words are not entered correctly. When “0” is entered in word 12 for checksum, “ERROR” is blanked and the manual threat data is passed to the ALIC unverified. When the “ERROR” indication is displayed on the DED, the HARM WPN page displays “???” in place of the character code of the threat table.

HARM Delivery Modes:

The HARM missile can be delivered using any of three operational delivery modes:

- 1) Position Known (POS)
- 2) Harm as a Sensor (HAS)
- 3) Data Link (DL) - This mode only available with an IDM installed

When HARM is the selected weapon, the HARM operational mode is selected by depressing OSB #1 on the HARM Weapon page to access the Mode Menu page (Figure 4-15). From the Mode Menu page select one of the following: POS (OSB #20), HAS (OSB #19), or DL (OSB #18) and return to the HARM Weapon page for that mode. Depressing cursor-Z also causes the HARM mode to change in the rotary sequence: POS, HAS, DL and back to POS, etc.

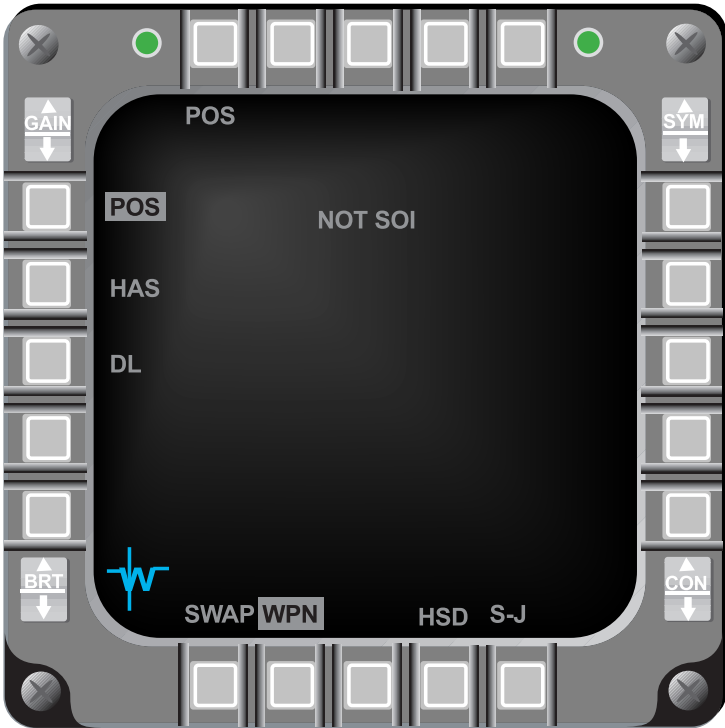

Figure 4-15 HARM Mode Menu Page

Position Known (POS) Mode:

In the POS mode, the aircraft attitude and target position are passed to the HARM. After launch the HARM flies to near the reported position of the target and then activates its seekerhead. The POS mode has the following flight profiles:

- 1) Equations of Motion (EOM): Provides threat specific off-axis capability with a narrow FOV when the seekerhead is activated.
- 2) Range Unknown (RUK): Provides threat specific off-axis capability with a wide FOV. Used when target range confidence is low. (Degraded state of EOM).

- 3) Pre-Briefed (PB): Provides location specific, on-axis capability with a wide FOV. PB is used for long range delivery with high confidence target location.

The controls and display information on the HARM Base page (Figure 4-16) are listed below:

Controls:

- 1) HARM Mode (OSB #1): Access Mode Menu page to select HARM mode (POS, HAS, or DL), or step through modes with cursor-Z
- 2) Primary Selected Threat Table (OSB #2): Steps through the three threat tables, or TMS left in POS or HAS
- 3) POS Flight Profiles (OSB #3): Steps through the three flight profiles (EOM, RUK, PB) or pinky switch on the sidestick in POS or DL
- 4) UFC Threat Table Access (OSB #5): Access selected HARM Threat Table on DED
- 5) Geographic Specificity (GS) (OSB #9): “GS ON/GS OF” Commands HARM to attack only a designated threat within a geographic region defined by a circle around the selected threat. It overrides the glide option of target isolate (Block IIIA only, GS is blanked for other HARM versions)
- 6) Target Isolate (TI) (OSB #10): Commands HARM to attack only the designated threat type and influences the approach by controlling the “flex” and “glide” missile characteristics. Uncage on the throttle also commands TI
- 7) Selective Jettison (S-J) (OSB #11): Jettisons the HARM (weapon only) or HARM and LAU-118 (weapon and launcher)
- 8) Threat Selection/Deselection (OSB #s 16-20): Selects/Deselects the threat to be handed-off to the missile as target type. The threat symbol highlights while threat information is handed-off and accepted. TMS right selects the first valid threat, a second TMS right steps to the next valid target. TMS aft deselects the currently selected threat.

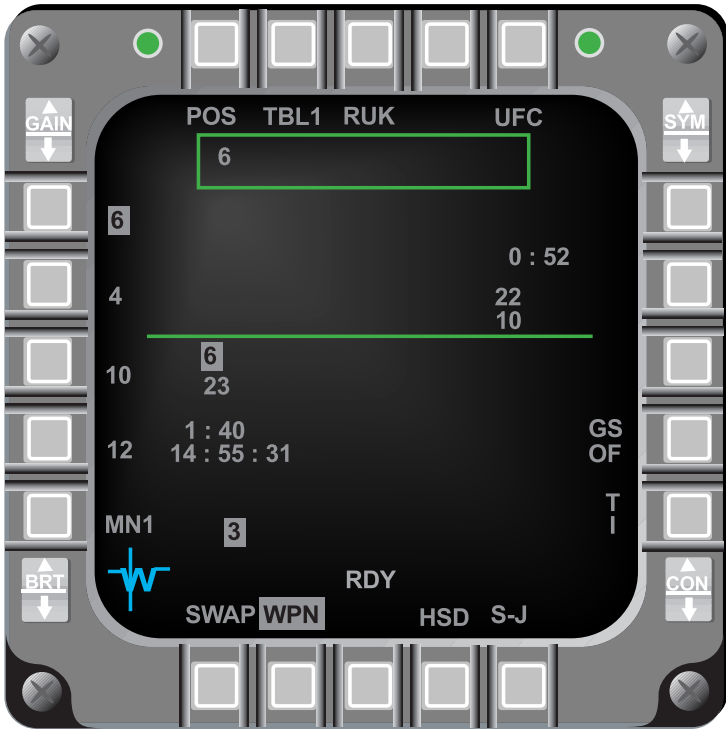

Figure 4-16 HARM POS WPN Delivery Page

Display Information:

Detected Threat Status Box (DTSB) is just below the top line of text and contains the threat that is handed-off, when detected by the missile. When deselected, the threat is blanked from the DTSB.

The center of the HARM WPN page contains missile employment information. It is divided into two sections by a Launch Status Divider Line (LSDL). Pre-launch information is displayed below the LSDL and directly above the selected missile station. Pre-launch information includes: the selected threat type, the selected threat position (steerpoint number), missile Time-of-Flight (TOF) in mm:ss format, Time-on-Target (TOT) in hh:mm:ss 24 hour format (TOT is not displayed in RUK mode), and HARM loaded stations (selected station is highlighted). The above data is displayed from top down.

Post-launch information is displayed above the LSDL in reverse order (bottom to top). Post launch includes: the threat type attacked, the threat location, and Time-Until-Impact (TUI). The TUI is displayed for five seconds after reaching zero (0:00) (TUI is not displayed in RUK mode). Post-launch data is retained and displayed until power is cycled or inventory is changed.

HUD symbology for HARM POS launches (Figure 4-17) is similar to symbology in the Continuously Computed Release Point (CCRP) delivery mode. Although HARM can be employed from a variety of delivery angles, loft is the preferred maneuver, therefore, the HUD display has been optimized for Loft deliveries.

The following HUD symbology is displayed in all HARM POS flight profiles unless stated otherwise:

- 1) Loft Solution Cues: Three loft solution cues are positioned on the Azimuth Steering Line (ASL). The large cue indicates the maximum aircraft climb angle at which the missile can make the required pull-down. The middle solution cue (> <)(PB only) indicates the optimal aircraft climb angle. The small solution cue indicates the minimum aircraft climb angle at which the missile can make the required pull-up. The solution cues are blanked from the ASL until reaching the maximum aircraft maneuver zone range (within the HLS). The Loft solution cue is not available in the RUK mode.
- 2) HARM Launch Scale (HLS): The HLS is displayed on the right side of the HUD.
- 3) Predicted Release Altitude: The predicted release altitude (AGL) above the target is at the bottom of the HLS (in hundreds of feet) shows where the aircraft will be if the pilot pulls up to the loft angle indicated next to the in-range cue (based on 4-G pull-up). Not available in the RUK mode.
- 4) Required Turn: The required turn angle to achieve missile launch conditions is displayed below the predicted release altitude. It represents the angle (0-99 degrees) left or right (L##, R##) required to bring the aircraft within the Missile Maneuver Zone (MMZ). Not available in the RUK and PB modes. When within the MMZ, it represents the angle to bring the target on the nose.
- 5) Time-To-Release (TTR): The TTR is displayed above the bearing and range to the target. TTR indicates the time to reach the edge of the launch envelope under current flight conditions. Once within the missile maneuver zone the TTR indicates zero.
- 6) Mode Display: HARM is displayed below the airspeed scale. HRMVIP is displayed when VIP is selected and HRMVRP is displayed when VRP is selected.
- 7) HARM FOV Box: A HARM unique box indicating in-range launch enable and the end game FOV is displayed in the lower half of the HUD. The box is 1.5 degrees tall and 4 degrees wide for the EOM submode and 8 degrees wide for the RUK and PB submodes. The box flashes when the HLS range cue is in the missile maneuver zone and has accepted the hand-off data.

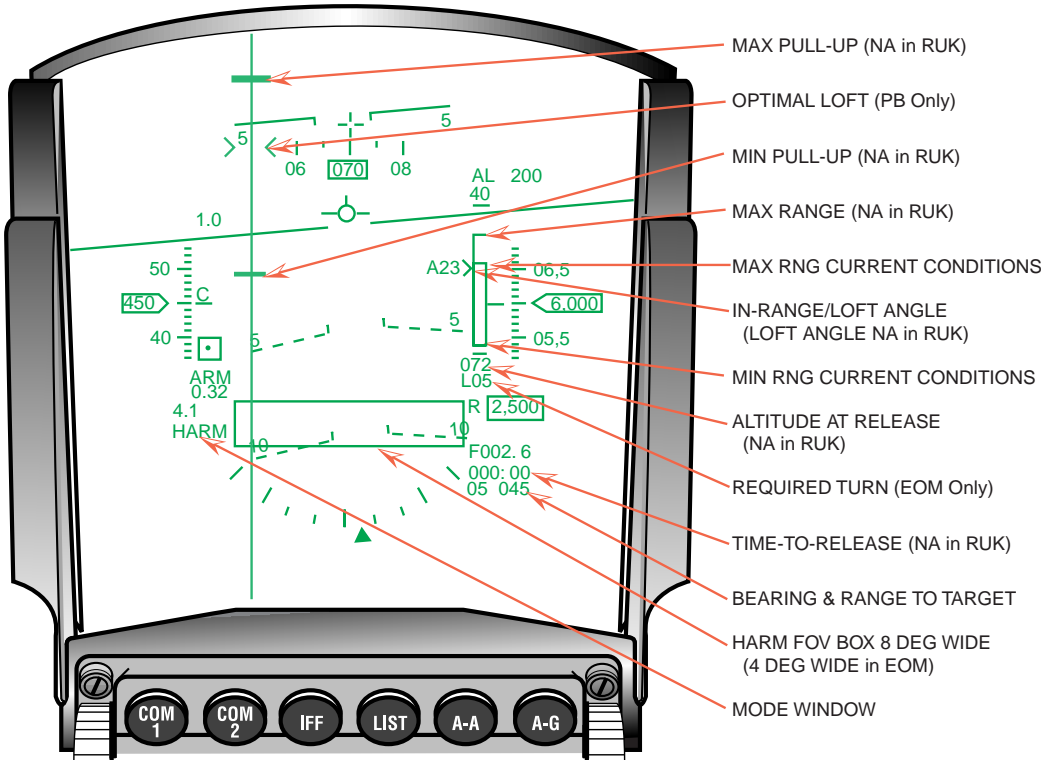

Figure 4-17 HUD POS Mode Symbology

HARM As Sensor (HAS) Mode:

The HARM provides seekerhead video to locate threats in the HARM HAS mode. The HAS WPN page (Figure 4-18) is the same as the POS WPN page except for the following controls and display information:

Controls:

- 1) The HAS Weapon page has no threat selection/deselection OSBs. The target threat is selected by designating (TMS Up) with the cursor over the specified Acquired Before Launch (ABL) threat on the ALIC video. The associated threat type highlights adjacent to OSB #s 16-20. Once a threat is selected the cursor is removed.
- 2) FOV Selection (OSB #3): The POS mode (OSB #3) is replaced in the HAS mode by the HARM FOV rotary. The selections are center (CTR), left (LT), right (RT), and wide (WIDE). The FOV initializes to wide at power up. The pinky switch also rotaries the FOV.
- 3) Search Select (SRCH) (OSB #4): Displays the Search Select page. Threats types can be deselected to reduce search scan time. The worst case cycle time for the selected (highlighted) threats is displayed as shown in Figure 4-18. Scan cycle time can also be reduced by reducing the HARM FOV.

- 4) Restart (RS) (OSB #7): Restarts the scan cycle and blanks all previously displayed threats on the Search Select page.

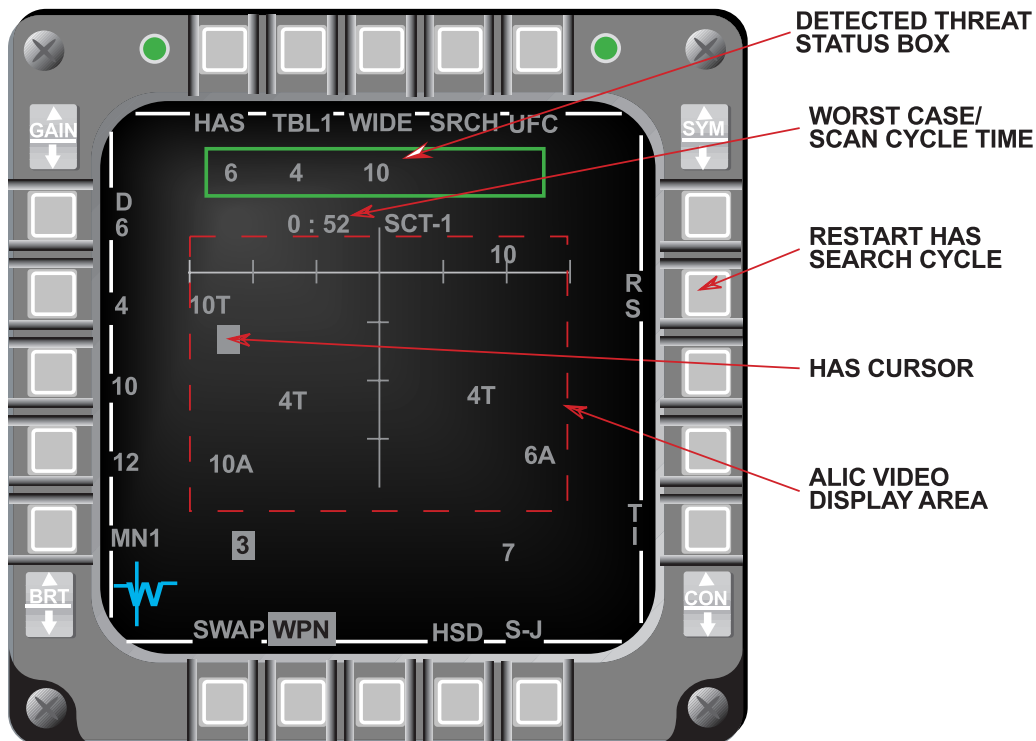

Figure 4-18 ALIC Video Display Before Hand-Off

Display information:

The Detected Threat Status Box (DTSB), near the top of the MFD contains the threat types detected by the HARM seekerhead. Detected threats are displayed left to right. After a threat hand-off, the detected threats remain displayed. Threats are blanked from the DTSB when no longer detected.

ALIC provided video of detected threats is displayed in the center of the HAS WPN page. The ALIC provides two video displays: 1) used for searching, and 2) used after hand-off. The initial video display before hand-off is shown in figure 4-18 above. Two threats can be displayed for each threat table entry, for a total of ten threats. If two threats are not detected for each threat table entry, more than two threats may be shown for the other table entries. The detected threats are displayed on the relative azimuth and elevation from the nose of the missile. When detected, the threats are displayed with an identification letter representing the radar type. If multiple radar types are detected for the same threat type at the same location, the identification letter is not displayed with the threat type number. Only the highest priority threat is displayed when multiple threat types are detected at the same location. Detected threats are stationary with respect to the ground as the aircraft rolls and pitches. Threats are displayed on the bottom line of the video when they go below the seekerhead FOV.

After a threat is handed-off to the HARM, the display (Figure 4-19) represents the missile boresight and the threat video responds to aircraft pitch, roll, and azimuth changes. “RDY” is dis-

played after the hand-off is complete. If the threat leaves the HARM FOV for more than 10 seconds, the hand-off is dropped, the ALIC returns to the search mode, and the display reverts back to the before hand-off format. If track is lost after the hand-off, the highlighted threat will flash. The designated threat is highlighted along with the threat type OSB label. The other detected threat types are blanked from the display.

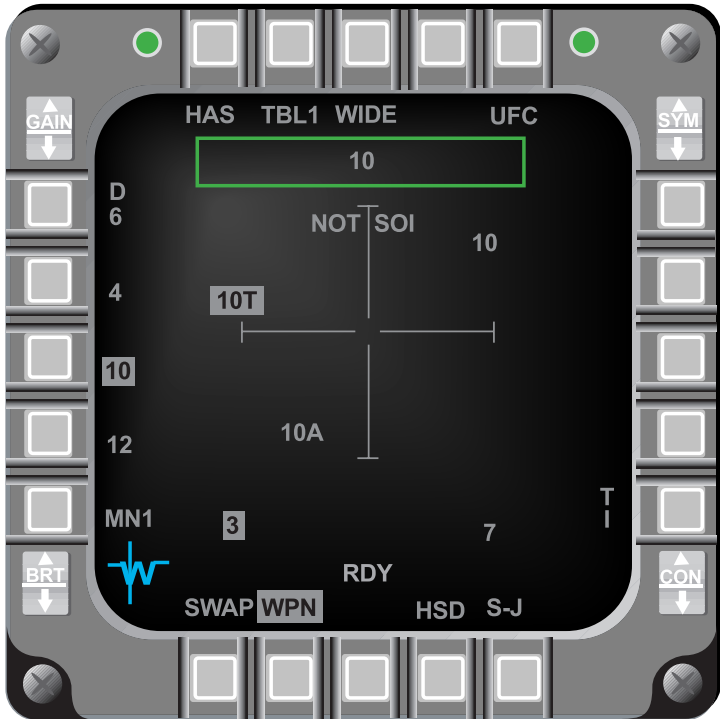

Figure 4-19 ALIC Video Display After Hand-Off

When the TMS right is depressed, the threat sub-types for the handed-off threat are stepped through and sent to the ALIC to perform a check to see if the threat is still radiating. This check is known as the Acquire Before Launch (ABL) confirmation. If the threat passes the ABL confirmation, the ALIC will preform another hand-off the data. While this second hand-off is occurring, “RDY” is dropped until the new hand-off is complete.

In the HAS mode, the HUD symbology (Figure 4-20) is similar to the NAV master mode with the following exceptions:

- 1) Mode Display: HARM, or HRMVIP is displayed below the airspeed scale to indicate aircraft mode of HARM, or VIP. VRP is not available in HAS.
- 2) HARM FOV Box: HARM FOV box is displayed the same as in POS/EOM.
- 3) VIP Selected: Range and steerpoint number is replaced by bearing and range to target.

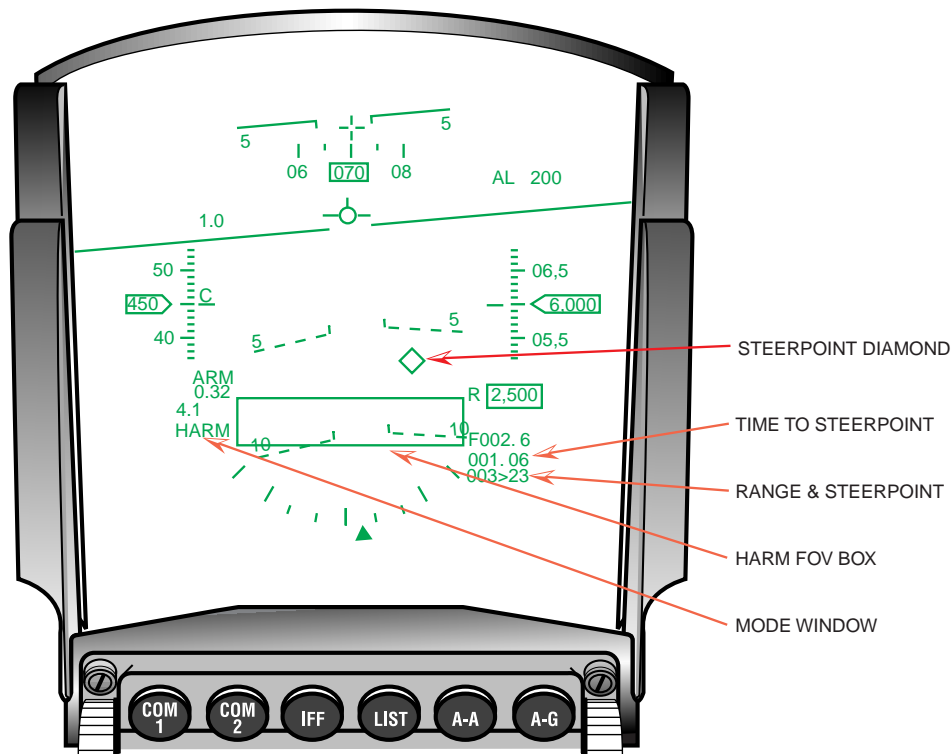

Figure 4-20 HARM HAS Mode HUD Symbology

HARM Data Link (DL) Mode:

The DL operational mode is available when the Improved Data Modem (IDM) is installed in the aircraft. The IDM can receive Suppression of Enemy Air Defense (SEAD) messages and provides the information to the HARM for targeting.

To receive SEAD messages via the IDM, the IDM communication protocol (A-G DL page) must be AFAPD. When the avionics system receives a SEAD message, the following indications are provided:

- 1) Distinct tones (dependent on the data rate) can be heard in the headset.
- 2) The mnemonic “SEADxx DATA” is displayed centered on the HUD.
- 3) A VMU message “DATA” is provided in the headset.

The “xx” in the HUD mnemonic indicates the steerpoint number in which the SEAD message is stored. The HUD mnemonic remains displayed until either Warn Reset is depressed and released, the DED DL SEAD page is displayed, or the HARM DL page is displayed on the MFDs.

When the FILL option is “ALL”, the system stores received SEAD messages in the following priority scheme:

- 1) If the system contains a SEAD message (in steerpoints 71-80) with the same message ID as the received SEAD message, that storage location is overwritten;

- 2) When no stored SEAD message has the same ID, the system stores the message in the first empty steerpoint (71-80) in increasing sequential order;
- 3) Lastly, if an empty steerpoint location is not available, the system stores the message in the location containing the oldest data link message, not selected for hand-off to the HARM missile

When the received data link message is a CAS Mission Update message containing both an IP and a TGT, the system stores the 2 locations in 2 contiguous steerpoints using a similar storage scheme:

- 1) If there is at least one empty pair of contiguous steerpoints (71-80), the system stores the IP and TGT locations in that steerpoint pair, sequentially (IP then TGT), in increasing steerpoint number and wrapping from 80 to 71;
- 2) Otherwise, if there is only one empty steerpoint, the IP is stored in the open steerpoint and the TGT is stored in the next increasing steerpoint location, wrapping from 80 to 71; the TGT position overwrites the data stored in that location;
- 3) Lastly, if an empty steerpoint location is not available, the system stores the IP in the location containing the oldest data link message, and the TGT is stored in the next increasing steerpoint location, wrapping from 80 to 71.

In the case where the CAS TGT overwrites a previous data link CAS IP, the TGT associated with the overwritten IP is also deleted from the system.

When the selected FILL option is NONE, the received SEAD message is discarded and no HUD or VMU advisories are provided. The system can store up to 127 SEAD messages on the DTE for post-flight data analysis (regardless of the FILL option).

SEAD Message Display (DED & HSD)

Received SEAD target locations are displayed on the SEAD Destination and Steerpoint pages (Figures 4-21&22). When the entered steerpoint (71-80) on any destination page contains SEAD data, the SEAD Destination page is displayed. The display includes steerpoint number, target latitude, longitude, elevation, and time-on-target.



Figure 4-21 DED SEAD Destination Page

The STPT page displays data for steerpoints 1-99. The data includes steerpoint number and sequencing mode, latitude, longitude, elevation, and time-over-steerpoint (Figure 4-22).



Figure 4-22 DED Steerpoint Page

A-G data link (GDLNK) symbology must be selected on the HSD Control page (OSB #17) to display the SEAD target position on the HSD. When a SEAD target is received, the target position is displayed on the HSD by mipping “DL” and the SEAD threat character code. The SEAD threat character code is an alpha-numeric code of up to 3 characters (Figure 4-23). The MFDs uses a Threat Symbology Table (TST), loaded from the DTE along with the Electronic Intelligence (ELINT) file, to determine the character code associated with the threat. The SEAD character code determination is summarized below.

- 1) The HSD displays the character code associated with the threat based on the TST.
- 2) “MN” is displayed for a manual threat. A valid manual threat is a threat that has been located but may not be currently defined by the TST.
- 3) “???” is displayed if the SEAD target is not found in the TST.
- 4) If the TST has not been loaded, the threat index number is displayed at the target location. The threat index number is a numeric sequence number that correlates to a character code to be displayed on the HSD.

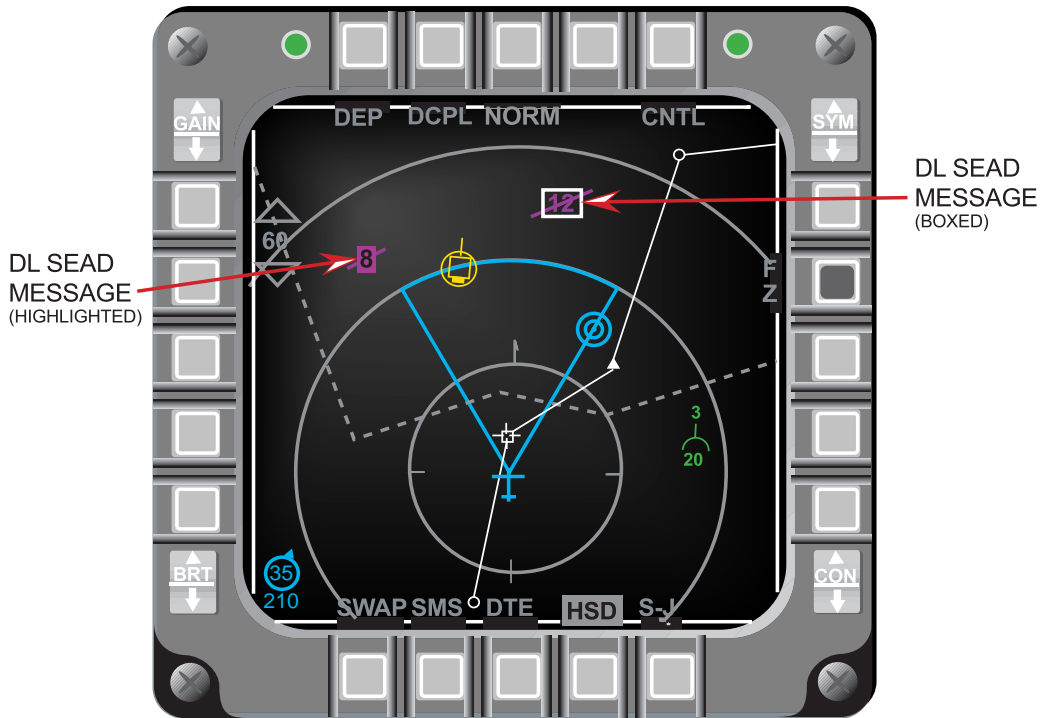

Figure 4-23 HSD SEAD Target Display

Depressing Warn Reset or selecting the mipping SEAD target as the DL TOI, stops mipping the SEAD characters and displays the character code over a slash (Figure 4-24) at the target position. There is no indication of a data link SEAD target position outside the HSD FOV until the SEAD target is selected as a DL TOI.

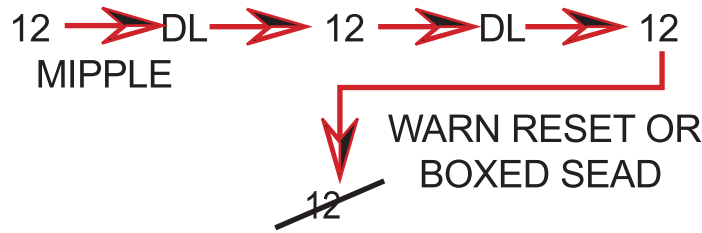

Figure 4-24 Data Link SEAD Character Code Display

SEAD Message Selection (Data Link Target of Interest (DL TOI))

A data link SEAD threat displayed on the HSD can be selected as the Data Link Target Of Interest (DL TOI) when the HSD is the selected SOI. There can be only one DL TOI. A data link CAS IP or CAS TGT can also be selected as a DL TOI on the HSD.

A box is displayed about the SEAD threat selected as the DL TOI. The avionics system provides a hands-on method of selecting a received SEAD target as the DL-TOI, displaying the DL-TOI on the DED DL SEAD page, and stepping among the received data link SEAD targets. The following summarizes the available hands-on operations using the TMS switch:

- 1) TMS Up (Designate): Selects the SEAD target as a DL TOI and displays a box about the symbol.
- 2) TMS Left: Displays the DED DL page for the DL TOI (Figure 4-25). If the DL TOI is a SEAD target the DED DL SEAD page is displayed.
- 3) TMS Right (no DL TOI): Selects the received data link SEAD message as the DL TOI. If the last received data link message was a SEAD message; a box is displayed about the SEAD target. If the target is outside the HSD FOV, the HSD automatically increases the range scale to a range sufficient to display the SEAD target position (up to 120 NM for depressed and 80 NM for the centered format). If the target position is still outside the FOV, the system displays a Data Link Target Outside FOV symbol (filled triangle), pointed outward along the outermost range ring at the bearing of the DL SEAD position. If the range rings are turned off, the filled triangle is displayed along the perimeter of the MFD at the bearing of the DL SEAD position.
- 4) TMS Right (with a DL TOI):
 - a) When a SEAD target is the DL TOI, TMS right steps the box to the next SEAD target in increasing display distance from the bottom of the HSD, and from right to left. When the farthest SEAD target is the DL TOI, TMS right wraps the TOI box back to the closest SEAD target on the HSD display. (NOTE: *the stepping function on the HSD is always from a SEAD to SEAD or a CAS to CAS target*). If the SEAD target being stepped to is outside of the FOV, the range scale is automatically increased.
 - b) When a DL TOI exists and it's not the last received data link target, TMS right for greater than 1 second selects the last received data link target as a DL TOI, whether the last received is a DL CAS IP, DL CAS TGT, or a DL SEAD. If the SEAD target being stepped to is outside of the FOV, the range scale is automatically increased.
- 5) TMS Aft:
 - a) TMS Aft \leq 1 sec: Drops the DL TOI (box) and displays the CNI page if a DL SEAD page was displayed, regardless of HSD cursor position.
 - b) TMS Aft $>$ 1 sec: Commands the zeroize message when a SEAD target is the DL TOI with the HSD cursor correlated with the SEAD target.

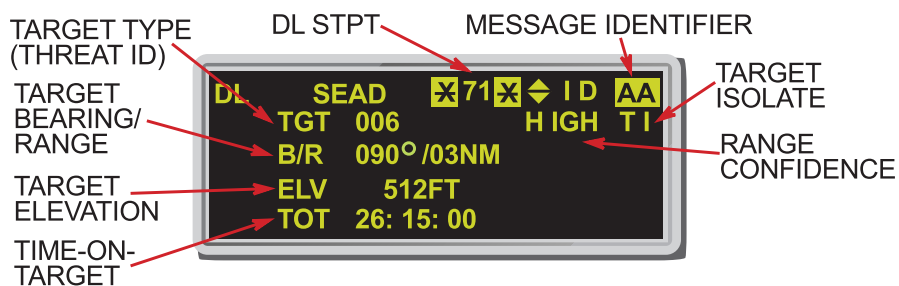

Figure 4-25 SEAD DL Page

When the DED DL SEAD page is displayed, INC/DEC or entering a DL SEAD STPT number (71-80) steps the DL STPT up or down to the selected DL SEAD message. When the DL STPT is changed, the SEAD box (TOI) on the HSD steps to the new SEAD target associated with the new DL STPT and the data on the DL SEAD page reflects the selected DL SEAD TOI. If a STPT (71-80) does not contain a DL SEAD target, that STPT is skipped. Hands-on selection of a new DL SEAD TOI (TMS right or Designate) updates the DL SEAD page with the new SEAD DL TOI data.

SEAD Message Transmission

When a DL SEAD target is selected as the DL TOI on the HSD, the SEAD target position and its characteristics can be transmitted to another properly equipped aircraft. The procedure for transmitting a DL SEAD message follows:

- 1) Enter the transmit address (XMT) on the A-G DL initialization page for the intended receiver (Figure 4-26).
- 2) Ensure the radio (COMM) and data rate (DATA) match the intended receiver. These selections must match for any DL communication.
- 3) Ensure the protocol (PRTL) is AFAPD. SEAD messages require the AFAPD protocol.
- 4) Place the SOI on the HSD, select the desired SEAD target as a DL TOI, and depress COMM Inboard on the throttle;
 - a) verify "XMT" highlights temporarily (OSB #6 on the HSD).
 - b) verify the A-G DL radio (UHF/VHF) highlights on the DED CNI page during DL transmission.
 - c) verify that a tone is heard in the headset for data rate 1200.

To receive DL SEAD messages ensure the:

- 1) Radio (COMM) and data rate (DATA) match the transmitter
- 2) Protocol (PRTL) is AFAPD.
- 3) Fill option (FILL) is ALL.

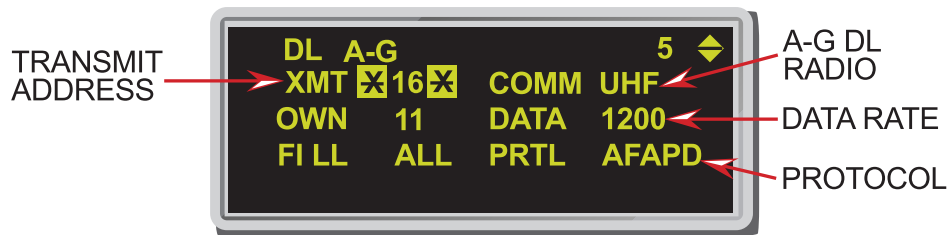

Figure 4-26 SEAD Message Transmission

SEAD Message Zeroize/Deletion

A stored SEAD message can be zeroized (deleted) from the system hands-off using the DL SEAD page or hands-on via TMS aft. Since the system stores new SEAD messages in an open location before overwriting, deleting SEAD messages clears the HSD display of unnecessary SEAD messages and creates open storage locations. To delete a SEAD message via the UFC, select the DL SEAD page and:

- 1) Position asterisks about the data link SEAD message
- 2) Depress mode select
- 3) verify the following data fields are blanked:
 - a) ID: message identifier
 - b) TGT: target type (threat ID)
 - c) B/R: bearing and range to SEAD target
 - d) ELV: target elevation
 - e) TOT: time on target.

Mark-84 Transonic Algorithm (RDP-612)

M2 provides improved accuracy for MK-84 deliveries in the transonic regime by adding the latest Seek Eagle data points to the MK-84 algorithm. The percentage of improvement in Circular Error Probability (CEP) under various conditions are listed in Table 4-1:

Table 4-1 Mark-84 CEP Improvement Percentages

MACH < 0.85	MACH > 0.85
Level, Dive (G < 1.7) Ground Plane	
15.5%	43.78%
LOFT, DTOS (G > 1.7) Ground Plane	
2.6%	41.3%

Update CBU-87 Algorithm (RDP-625)

The CBU-87 algorithm was changed to account for a known proximity fuze bias and to update separation effects coefficients. The percentage improvement in CBU-87 CEP for various deliveries and rack ID's are shown in Table 4-2:

Table 4-2 CBU-87 CEP Improvement Percentages

RACK ID	ATRK BIAS	CEP
G-LOADED DELIVERIES		
12 (MAU)	88.3%	19.6%
20 (TER)	100.4%	16.3%
1-G DELIVERIES		
12 (MAU)	149.7%	10.1%
20 (TER)	105.6%	10.1%
ALL DELIVERIES		
12 (MAU)	96.7%	19.0%
20 (TER)	99.1%	14.7%

THIS PAGE INTENTIONALLY LEFT BLANK

SECTION 5 - DEFENSIVE AVIONICS

This section introduces the following Defensive Avionics enhancements:

- Selectable Threat Range Rings On The HSD
- Report Jamming Of AIFF Frequencies

Selectable Threat Range Rings On The HSD (RDP-967)

This change provides for hands-on declutter of individual preplanned threat range rings and the ability to make a preplanned threat the current steerpoint. Threat range rings are only available for preplanned threats when PRE (OSB #2) is selected on the HSD Control page, and all threat range rings are displayed by default. Placing the cursor over a preplanned threat (Figure 5-1) and TMS aft will declutter the threat range ring for that threat. TMS forward with the cursor on a decluttered threat will display the threat's range ring. TMS forward on a preplanned threat with the threat range ring displayed selects the threat's location as the current steerpoint. A double TMS forward is required to select a preplanned threat that is not displaying its threat range ring. TMS forward with the cursor over any steerpoint selects that steerpoint as the current steerpoint. Individual preplanned threat range ring status is retained (last left) through deselection and selection of preplanned threats.



Figure 5-1 HSD Threat Ring Display

Report Jamming Of AIFF Frequencies (RDP-880)

The AIFF jamming (IJAM) option selects the jamming indicators “I” and “IFF JAM” for display on the FCR pages when noise is detected by the AIFF transponder. Entering 7 in the

scratch pad on the INTG DED pages (Figure 5-2) toggles the AIFF jam enable/disable selection and highlights/dehighlights the IJAM label. The interference indicators are displayed for 1.5 seconds for LOS interrogations and 2 seconds for SCAN interrogations.



Figure 5-2 DED INTG Pages

When IJAM is enabled the AIFF reports the jamming azimuth angle. A red “I” indicates interference on the FCR display (Figure 5-3). The position of the “I” indicates the azimuth direction of the jamming. Eight jamming indicators or a combination of up to seven jamming indicators and up to 32 target replies can be displayed. If a jamming indication is detected in a beam area where no targets are detected, a jamming indicator is reported for that beam area. If a jamming indication is detected in a volume overlapped by two beams the indicator is displayed in both beam areas. Each AIFF beam is 30 degrees in azimuth and the beams overlap. “IFF JAM” is also displayed in the center of the FCR page along with the interference indicators.

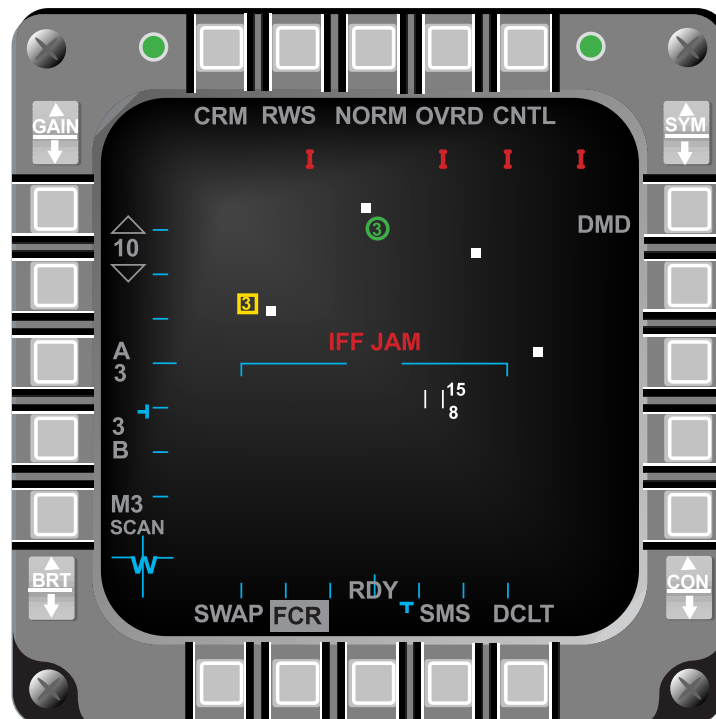

Figure 5-3 FCR AIFF Jamming Indications

The jamming indicators are also displayed on the A-G FCR Base page in the following FCR modes, 1) GM, 2) GMTI, 3) SEA, and 4) BCN.

INDEX

600 gallon tanks 4

A

A-A 42, 47, 48, 51, 70, 71, 75, 79, 113
 AAA 49, 113
 AACMI 5, 113
 FACE 5
 AAF 70
 ABL 92, 94
 ACAL 77, 78, 113
 ACM 31, 45, 48, 113
 ACM Boresight 48
 ACQ 22, 113
 Acquire Before Launch 94
 Acquisition mode 17
 active Nav route 26
 ADL 48, 113
 Advanced IFF 32
 AFAPD 38, 39, 41, 95, 100, 113
 A-G 70, 71, 75, 78, 79, 83, 95, 97, 100, 105,
 113
 AGR 77, 113
 AIFF 32, 104, 105, 113
 IJAM 104, 105
 AIFF auto time 32
 AIM-9 31, 48, 55
 AIM-9 DLZ 61
 AIM-9L/M 31, 54, 56
 Air to Ground Ranging 32
 ALIC 84, 87, 92, 93, 94
 Allowable Steering Error Circle 58
 ALOW 18
 AMRAAM 31, 56, 62, 63, 65, 66, 67, 113
 Inert Test Vehicles 64
 LOSE indications 67
 AMRAAM DLZ 56, 57, 59, 60, 61
 AMRAAM loft 58
 AREA Track 77
 Area Track 70
 Armament Datum Line 48
 ASC 58
 ASEC 58

ASGN 42
 ASL 91
 ASSIGN 44
 Assign 42
 assignment 37
 ATHS 113
 Attack Steering Cue 58
 Attitude Advisory Function 70
 Attitude Awareness Arc 49
 attitude awareness arc 49
 Auto ACAL 18
 AUTO Acquisition 55
 AUTO IFF 33
 Automatic Target Hand-Off System 31
 Autonomous Air Combat Maneuvering Instru-
 mentation 5
 avionics system 55
 Azimuth Steering Line 91

B

Backup Bombing Sensor 22
 BARO 113
 BATR 54
 BBS 22
 BCN 113
 Beacon 32
 bearing and range 46, 47
 BHOT 73, 79
 Black Hot 70
 Black Track 73
 BORE 54, 55, 113
 Break 18
 Break X 19
 breaklock 63
 BT 73, 79
 Bug stepping 45
 bull's-eye 46, 47
 Bullets At Target Range 54

C

CAS 41, 43, 44, 96, 98, 99, 113

CAS message 39
 CBU-87 70, 102
 CCRP 90
 CEP 101, 102
 Circular Error Probability 101
 Close Air Support 37
 CMFD 6, 113
 color palette 6
 C-Mux bus 5
 CNI 4
 CNI page 99, 100
 Coast 51
 Color Multi-Function Display 6
 color palette
 primary additive colors 6
 primary subtractive colors 6
 symbol color, default colors 6
 COMM 2 4
 Computed Rates 77
 CONT 42
 Continuous 31
 couple 32
 Cruise Time 28
 CRUS TOS 29, 30

D

D/L 8, 114
 Data Base Terrain Cueing 15
 Data Link 8, 31, 99
 Data link 37, 43
 Data Link Steerpoints 31
 Data Rate 38
 Data Transfer Cartridge Loader/Reader 6
 Data Transfer Equipment 25
 DBTC 18, 19, 20, 21, 23, 114
 DBTC cue 23
 DCS 86
 decouple 32
 DED 6, 13, 16, 27, 28, 29, 30, 42, 52, 95, 96,
 97, 98, 99, 100, 105, 114
 AIFF Time (TIM) page 32
 CRUS TOS page 13
 Laser page 27
 Time page 13
 default colors 6

DEMAND 37
 Detected Threat Status Box 90
 DFM 17, 19, 22, 23
 DGFT 31, 49, 114
 Digital Flight Map 17
 Digital Terrain System 15
 Digital Terrain System Application Software
 20
 DL 42, 43, 88, 95, 97, 98, 99, 100, 101, 114
 DL SEAD 44
 DL TOI 32
 DLZ 48, 64, 65, 66, 67, 83, 114
 DMD 114
 DTC 6, 29, 114
 L/R 6
 DTE 25, 27
 load 27
 DTED 23
 DTS 15, 16, 17, 18, 20, 21, 22, 23, 114
 DTS/DTC 22
 DTSACQ 16, 17
 DTSB 90, 93
 DTSFIX 16

E

EACMI 5
 EEGS 31, 53, 54, 114
 Electronic expansion 70
 Electro-Optic 83
 ELINT 97
 E-O 83
 EOM 88, 94
 Equations of Motion 88
 EWMS 81

F

FAC 114
 Fatigue/Air Combat Evaluator 5
 FCR 4, 10, 12, 32, 42, 45, 46, 48, 51, 55, 66,
 73, 79, 104, 105, 114
 cursor minimum search altitude display 46
 FCR EXPAND 47
 FEDS 31, 53, 54
 Field Of View 8

Filter Mode 16
 Firing Evaluation Display System 53
 Fixed Target Track 32
 flight path marker 21
 FLIR 26, 70
 Base page 26
 Forward Looking Infrared 70
 Friendly 12
 FTT 32, 114

G

GDLNK 97, 115
 GHF 49, 50, 115
 Ghost Horizon Line 49
 GMTI 32
 GND PROX 18
 GPS 13, 15, 16, 18
 time 13
 Ground Map 32
 Ground Moving Target Indicator 32

H

HARM 56, 70, 84, 85, 86, 88, 90, 92, 93, 95,
 96, 115
 acquired before launch 92
 Aircraft Launcher Interface Computer 84
 ALIC 84
 Command Destruct 85
 DL 88, 95
 Gyro Test 85
 HAS 88, 92
 HTV 84
 Launch scale 91
 POS 88, 90
 Equations of Motion 88
 Geographic Specificity 89
 Pre-briefed 89
 Range unknown 88
 Target isolate 89
 Tertiary Table 85
 threat code ID 87
 Threat table 86
 HARM Launch Scale 91

HARM Threat Table 86
 HAS 88, 94
 HAT 81, 83, 115
 Height Above Target 22
 Height-Above-Target 81
 High Speed Anti-Radiation Missile 84
 HLS 91
 horizon line 9
 Horizontal and Vertical Confidence 15
 Horizontal Range Known 22
 Horizontal Situation Display 8
 HSD 4, 8, 12, 15, 23, 24, 25, 32, 39, 42, 43,
 44, 96, 97, 98, 99, 100, 101, 104, 115
 Control page 25
 control page 25
 displays 12
 FOV 8
 Freeze 23, 25
 HSD Declutter 15
 HSD Freeze 15
 HTV 84, 85
 HUD 15, 17, 18, 19, 21, 27, 28, 29, 30, 32, 46,
 47, 48, 49, 51, 52, 54, 55, 56, 58, 59, 60,
 61, 66, 67, 77, 78, 79, 82, 83, 84, 90, 94,
 95, 96, 115
 Total Field Of View 49
 HUD Symbology
 Landing Phase 15

I

IDL 115
 IDM 31, 95, 115
 Zeroize 31
 IDM Data Link 32
 IFF 104, 105, 113, 115
 IJAM 32
 ILS 28
 Improved Data Modem 42
 In-Flight Alignment 16
 Infrared 70
 INS 16, 18, 30, 79, 81, 83, 115
 interrogator codes 33
 interrogator modes 33
 IR 70

J-K

jamming azimuth angle 105

L

LANTIRN 70, 71, 78
 Point Track 48
 TGP 10, 75, 77, 79, 117
 LANTIRN navigation pod 77
 LANTIRN Targeting Pod 31, 47, 70
 LANTIRN TGP 71
 LAP 84
 Laser Ranging 48
 Laser Spot Locator 15, 27
 Launch Status Divider Line 90
 Launcher Avionics Package 84
 LIST 5, 27
 LO TC 21
 Loft solution cue 91
 LOS interrogation 36
 LSDL 90
 LSL 15, 27

M

Maneuver Potential Lines 52
 MARK 78
 markpoint 44
 mask zone 77
 Master Format Menu page 72
 master mode 25, 27
 Master Navigation Filter 15
 Maverick 70, 78, 83
 Maverick missile 78
 Maverick video 84
 max in-range dot 52
 MFD 4, 9, 10, 11, 58, 59, 60, 61, 67, 70, 71,
 79, 80, 82, 83, 87, 99
 Brightness 4, 11
 brightness 10, 70, 113
 Contrast 4, 11
 contrast 10, 70, 114
 formats 10
 Intensity 10, 11
 Rocker switches 10

Minimum Terrain Clearance 18
 missile ID number 66
 Missile Launch Envelope 51, 83
 Missile Step 54
 MK-84 101
 MLE 51
 MMC 5, 18, 20, 53, 54, 67, 81, 116
 OFP 5
 MNF 17
 Mode Menu page 88
 Mode-Select 5
 Modular Mission Computer 30
 MPLs 52
 MRGS 31, 51
 M-SEL 5
 MTC 18, 19
 Multi-Function Display 9
 multiple mode interrogations 36

N

NARO 75
 NAV 94
 Navigation Pod 26
 Net Size 31
 Neutral Track 73
 Night Vision Imaging System 6
 NO GPW 16, 17
 No Lock Training 54
 NT 73, 79
 NVIS 6
 NVP 26
 Boresight 15, 26, 55

O

obstacle 19
 Obstacle Warning and Cueing 15
 OFF MAP 17
 OFP 5, 51, 52, 71, 116
 On Station 37, 38, 40
 Operational Flight Program 71
 Optical Fields of View 70
 OW/C 19
 ownship symbol 44

P-Q

Passive Ranging 15, 22
 PB 89
 Penguin 78, 116
 penguin use rotary 78
 PGCAS 16, 17, 18, 19, 116
 MTC 116
 PGU-28 52, 82
 Pilot Vehicle Interface 3
 POINT Track 76
 POINT track 77
 Point Track 70
 POS 33, 34, 88, 90, 92, 94
 PR 22
 Predictive Ground Collision Avoidance Sys-
 tem 15
 preplanned delivery 78
 protocol 38, 100

R

RALT 116
 RECCE 70, 80, 81, 116
 RECCE Base page 80
 roll stabilized 23
 RUK 88, 90

S

SCAN interrogation 36
 Sea 32
 SEAD 31, 43, 44, 85, 95, 96, 97, 98, 99, 100,
 101, 117
 SEAD DL 43
 Search Select 92
 Selective Jettison 89
 Situation Awareness Indicator 74
 SLAVE 54, 55
 SMS inventory 56
 SMT 31, 45
 Snowplow 73
 SOI 23, 24, 25, 48, 55, 70, 84, 98, 100, 117
 STPT 39
 Strafe pipper 82
 strafe pipper 82

system time 13
 system track targets 12

T

TACFIRE 38, 41, 117
 tail flash 64
 tail symbol 62
 Target Designator 48
 Target Locator Line 48, 51, 78
 Target Management Switch 32
 Target Of Interest 8, 67
 Targeting Pod 32, 70
 TCH 18, 20, 21, 117
 TD 51
 Team Address 43
 Team Member 43
 team member 44
 Terrain Clearance Height 18
 Terrain Reference Navigation 15
 TFOV 49, 117
 TGP 32, 47, 48, 55, 70, 71, 72, 73, 74, 75, 76,
 77, 78, 79
 Display Polarity 73
 Gray Scale 73
 Sighting Point 73
 Snowplow 73
 Tracking Polarity 73
 TGP LOS 48
 The TGP 70
 threat range rings 104
 threat symbology table 97
 TIM 33
 Time-Over-Steerpoint 15
 TLL 48, 51, 78, 79, 117
 TMS 32
 TOF 90
 TOI 8, 42, 43, 67, 98, 99, 100
 TOS 30
 TOT 90
 track 55, 75
 Transmit Address 38
 TRN 15, 17
 TST 97
 TUI 90
 TV 3, 79

U

UFC 5, 27, 29, 32, 37
Universal Transverse Mecator 30
Unknown 12
Up-Front Controls 5
UTM 15, 30

V

Vertical Velocity Propagator 18
VHF radio 4
 8.33 kHz 4
 FM frequency 5

visual delivery 78
VMU 95, 96

W-X-Y-Z

Whiskers 23
whiskers 21
White Hot 70
White Track 73
WHOT 73, 79
WIDE 75
WT 73, 79

ABBREVIATIONS & ACRONYMS

A		AUTO	automatic
A-A	air-to-air		B
A-G	air-to-ground		
A/S	airspeed	B/R	bearing and range
AAA	attitude awareness arc	BAF	Belgium Air Force
AACMI	autonomous ACMI	BARO	barometric
AAF	attitude advisory function	BATR	bullets at target range
AAM	air-to-air missile	BBS	backup bombing sensor
ABL	acquired before launch	BCN	beacon
ABRT	abort	BHOT	black hot
ACAL	altitude calibration	BIT	built in test
ACCUR	accuracy	BORE	boresight
ACM	air combat mode	BP	backup
ACMI	air combat maneuvering instru- mentation	BPS	bits per second
ACQ	acquisition	BRG	bearing
ADL	armament datum line	BRK	breaklock
ADLNK	A-A datalink	BRT	brightness
AFAPD	Air Force applications develop- ment	BSGT	boresight
		BT	black track
			C
AGC	automatic gain/level control	C	correlation
AGL	above ground level	CADC	Central Air Data Computer
AGR	air-to-ground ranging	CAS	close air support/calibrated air- speed
AIFF	advanced IFF		
AIM	airborne intercept missile	CBU	cluster bomb unit
AL	altitude low	CCP	configuration/contract change proposal
ALIC	aircraft launcher interface com- puter	CCIP	continuously computed impact point
ALOW	altitude low	CCRP	continuously computed release point
ALT	altitude	CD	command destruct
AM	amplitude modulation	CDRL	contract delivery requirements list
AMMO	ammunition	CEP	circular error probability
AMRAAM	advanced medium range air-to- air missile	CLR	clear
ASC	attack steering cue	CMFD	color multifunction display
ASEC	allowable steering error circle	CNI	communications, navigation, IFF
ASG/ASGN	assign		
ASL	azimuth steering line		
ATHS	automatic target hand-of system		
ATRK	along track		
AUD	audio		

G		ILS	instrument landing system
G	gravitational unit/gain	IMNT	imminent
GAAF	ground avoidance advisory function	INC	increment
GBU	guided bomb unit	INS	inertial navigation system
GDLNK	ground datalink	INTG	interrogation
GEO	geosynchronous earth orbit	INV	inventory
GHL	ghost horizon line	IP	initial point
GM	ground map	IR	infrared
GMTI	ground moving target identification	ITV	integration test vehicle
GND	ground	J-K	
GPS	global positioning system	KCAS	knotts calibrated airspeed
GPW	ground proximity warning	KHz	kilo-hertz
GS	geographic specificity	L	
GT	gyro test	L	low / left / lamberts
H		L/R	loader/reader
H	high/horizontal	LADD	low angle drogue delivery
HARM	highspeed anti-radiation missile	LANTIRN	low altitude navigation and targeting infrared for night
HAS	HARM as sensor	LAP	launcher avionics package
HAT	height above target	LASR	laser
HB	High Bandwidth	LAT	latitude
HDG	heading	LAU	launcher
HDPT	hardpoint	LB	Low Bandwidth
HLS	HARM launch scale	LGB	laser guided bomb
HR	horizontal range	LM AERO	Lockheed-Martin Aeronautics Company
HRM	HARM	LNG	longitude
HSD	horizontal situation display	LO TC	low terrain clearance
HTV	HARM test vehicle	LOS	line of sight
HUD	head up display	LSDL	launch status divider line
Hz	hertz	LSL	laser spot locator
I		LT	left
ICAO	International Civil Aviation Organization	M	
ICP	integrated control panel	M	medium / meter
ID	identification	M-SEL	mode select
IDL	intraflight data link	MAL	malfunction
IDM	improved data modem	MAN/MN	manual
IFA	in-flight alignment	MFD	multi-function display
IFF	identification friend or foe	MGC	manual gain/level control
IJAM	IFF jamming	MHz	mega-hertz

MIN	minutes/minimum		
MISC	miscellaneous		
MKPT	markpoint		
MLE	missile launch envelope	P/T	position & time
MLU	mid-life update	P/PENG	Penguin
MMC	mission modular computer	PB	pre-briefed
MMZ	missile maneuver zone	PFL	pilot fault list
MN	manual	PGCAS	predictive ground clearance avoidance system
MNF	master navigation filter	POS	position known
MPLS	maneuver potential lines	PR	passive ranging
MPRF	medium pulse rate frequency	PRE	preplanned
mr	milli-radian	PRF	pulse rate frequency
MRGS	multiple reference gunsight	PROF	profile
MRL	missile rail launcher	PROG	program
MRLW	missile rail launcher with track adapter	PROX	proximity
MRM	medium range missile	PRTL	protocol
MSL	mean sea level	PVI	pilot vehicle interface
MSMD	master mode	PWR	power
MSN	mission		
MTC	minimum terrain clearance		
MTI	moving target indices		
MUX	multiplex		
			Q-R
	N	R	radar altitude / right
N	North	R _{AERO}	kinematic range
NA	not applicable/not available	R _{MAX}	maximum range
NARO	narrow	R _{MIN}	minimum range
NAV	navigation	R _{OPT}	optimum range
NM	nautical mile	R _{PI}	probable intercept range
NORM	normal	R _{TR}	turn and run maneuver range
NT	neutral track	RAD	radiate
NVIS	night vision imaging system	RADA	the FACE system is referred to as RADA
NVP	navigation pod	RALT	radar altimeter
		RCD	record
	O	RDAF	Royal Danish Air Force
OA	offset aim-point	RDP	requirements development package
OFP	operational flight program	RDR	radar
OFST	offset	RDY	ready
OPER	operation	RECCE/	
OSB	option select button	RCCE	reconnaissance
OVRD	override	REQ	required
OW/C	obstacle warning and cueing	RF	radio frequency
		RMK	remarks
		RNG	range
		RNLAF	Royal Netherlands Air Force

ROE	rules of engagement	TCH	terrain clearance height
RP	release point	TD	target designator
RS	restart	TEMP	temperature
RST	reset	TER	tertiary
RSU	rate sensor unit	TF _{MAX}	maximum time of flight
RT	right	TFOV	total field of view
RTN	return	TFR	terrain following radar
RTS	return to search	TGP	targeting pod
RUK	range unknown	TGT	target
RWS	range while search	THLD	threshold
		TI	target isolate
	S	TIM	time
S-J	selective jettison	TLL	target locator line
SAI	situation awareness indicator	TMS	target management switch
SAM	situation awareness mode	TNG	training
SBC	symbology/brightness/contrast	TOF	time of flight
SCOR	score	TOI	target of interest
SEAD	suppression of enemy air defense	TOS	time over steerpoint
sec	second	TOT	time-over-target
SEQ	sequence	TRK	track
SMS	stores management system	TRN	terrain referenced navigation
SMT	SAM multi-track	TRP	traped
SOI	sensor of interest	TST	threat symbology table
SP	snowplow	TTR	time-to-release
SPAR	system problem anomaly report	TTS	two target SAM
SPI	system point of interest	TUI	time-until-impact
SRCH	search	TV	television
SRM	short range missile	TWS	track while scan
STA	station		U
STBY	standby	UFC	up-front control
STOR HDG	stored heading	UHF	ultra-high frequency
STP/STPT	steerpoint	UNK	unknown
STRF	strafe	USAF	United States Air Force
STT	single target track	UTM	universal transverse mercator
SYM	symbology		V
SYS	system		
	T	V	vertical
T.O.	technical order	V _{max}	velocity (maximum)
TACFIRE/		V/INST	vehicle for instrumentation
TACF	tactical fire direction	VHF	very-high frequency
TBL	table	VID	visual identification
TC	terrain clearance	VIP	visual initial point

VIS	visual	WPN	weapon
VMU	voice message unit	WSPAN	wing span
VRP	visual release point	WT	white track
VS.	versus		
VVP	vertical velocity propagator		X-Y
	W	XMT	transmit
WCP	worst case profile		Z
WHOT	white hot		
WOW	weight on wheels	Z-VEL	zero velocity